

---

# INGERSOLL-RAND®

---

## OPERATING, MAINTENANCE, PARTS MANUAL

### COMPRESSOR MODEL

HP600WJD

XP750WJD

HP750WJD

XP825WJD

Code:



This manual contains important safety information.

Do not destroy this manual.

This manual must be available to the personnel who operate and maintain this machine.

**INGERSOLL-RAND®**

**AIR COMPRESSORS**

Portable Air Compressor Division  
P.O. Box 868 - 501 Sanford Ave  
Mocksville, N.C. 27028

---

# ***QUALITY POLICY***

*We will supply products and services that consistently meet the requirements of our customers and each other.*

## **CALIFORNIA**

### **Proposition 65 Warning**

**Diesel engine exhaust and some of its constituents are known to the State of California to cause cancer, birth defects, and other reproductive harm.**

# Foreword

Machine models represented in this manual may be used in various locations worldwide. Machines sold and shipped into European common market countries requires that the machine display the EC Mark and conform to various directives. In such cases, the design specification of this machine has been certified as complying with EC directives. Any modification to any part is absolutely prohibited and would result in the CE certification and marking being rendered invalid. A declaration of that conformity follows:

## ***Declaration of Conformity***

**WITH EC DIRECTIVE  
98/37/EC**

**Ingersoll-Rand Company  
P.O. Box 868  
501 Sanford Avenue  
Mocksville, North Carolina 27028**

**We  
Represented In EC By:**

**Ingersoll-Rand Company Limited  
Swan Lane, Hindley Green  
Wigan WN2 4EZ  
United Kingdom**

**Declare that, under our sole responsibility for manufacture and supply, the product(s)**

|           |           |            |            |            |
|-----------|-----------|------------|------------|------------|
| HP1300WCU | VHP825WCU | XHP900WCAT | VHP750WCAT | XHP1070CAT |
| XP1400WCU | HP935WCU  | XHP650WCAT | VHP850WCAT | NXP1300WCU |
| P1600WCU  | XP1050WCU | XHP750WCAT | HP900WCAT  |            |
| XP900WCU  | HP825WCU  | XHP825WCAT | XP1000WCAT |            |

**To which this declaration relates, is (are) in conformity with the provisions of the above directives using the following principal standards**

**EN1012-1, EN29001, EN202, EN60204-1  
PN8NTC2, EN 50081, EN50082**

**Issued at Mocksville on 1-1-95**

  
\_\_\_\_\_  
**Ric Lunsford  
Manager of Quality Control**

**Issued at Hindley Green on 1-1-95**

  
\_\_\_\_\_  
**H. Seddon, Q.A. Manager**

---

Nothing contained in this document is intended to extend any promise, warranty or representation, expressed or implied, regarding the Ingersoll-Rand products described herein. Any such warranties or other terms and conditions of sale of products shall be in accordance with the standard terms and conditions of sale for such products, which are available upon request.

This manual contains instructions and technical data to cover all routine operation and scheduled maintenance tasks by operation and maintenance staff. Major overhauls are outside the scope of this manual and should be referred to an authorized Ingersoll-Rand service department.

All components, accessories, pipes and connectors added to the compressed air system should be:

- of good quality, procured from a reputable manufacturer and, wherever possible, be of a type approved by Ingersoll-Rand.
- clearly rated for a pressure at least equal to the machine maximum allowable working pressure.
- compatible with the compressor lubricant/coolant.
- accompanied with instructions for safe installation, operation and maintenance.

Details of approved equipment are available from Ingersoll-Rand Service departments.

The use of repair parts other than those included within the Ingersoll-Rand approved parts list may create hazardous conditions over which Ingersoll-Rand has no control. Therefore, Ingersoll-Rand cannot be held responsible for equipment in which non-approved repair parts are installed.

Ingersoll-Rand reserves the right to make changes and improvements to products without notice and without incurring any obligation to make such changes or add such improvements to products sold previously.

The intended uses of this machine are outlined below and examples of unapproved usage are also given. However, Ingersoll-Rand cannot anticipate every application or work situation that may arise. **If in doubt, consult supervision.**

This machine has been designed and supplied for above ground operation to be used for compression of normal ambient air containing no additional gases, vapors or particles within the ambient temperature range specified in the general data section of this manual.

**This machine should not be used:**

- A. For direct or indirect human consumption of the compressed air.
- B. Outside the ambient temperature range specified in the general data section of this manual.
- C. When an actual or foreseeable risk of hazardous levels of flammable gases or vapors exists.
- D. With other than Ingersoll-Rand approved components.
- E. With guards, or controls or switches missing or disabled.
- F. For storage or transportation of materials inside or on the enclosure.

This company accepts no responsibility for errors in translation of this manual from the original English version.

---

# TABLE OF CONTENTS

**SECTION 1 ..... SAFETY**

**SECTION 2 ..... WARRANTY/REGISTRATION**

**SECTION 3 ..... NOISE EMISSION**

**SECTION 4 ..... GENERAL DATA**

**SECTION 5 ..... OPERATION**

**SECTION 6 ..... MAINTENANCE**

**SECTION 7 ..... LUBRICATION**

**SECTION 8 ..... TROUBLESHOOTING**

**SECTION 9 ..... PARTS ORDERING**

**SECTION 10 ..... PARTS LIST**

**SECTION 11 ..... OPTIONS PARTS LIST**

**SECTION 12 ..... ENGINE**

---

# SECTION 1- SAFETY

## SAFETY PRECAUTIONS

### **General Information**

Ensure that the operator reads and understands the decals and consults the manuals before maintenance or operation.

Ensure that the Operation and Maintenance manual, and the manual holder if equipped, are not removed permanently from the machine.

Ensure that maintenance personnel are adequately trained, competent and have read the manuals.

Make sure that all protective covers are in place and that the canopy/doors are closed during operation.

The specification of this machine is such that the machine is not suitable for use in flammable gas risk areas. If such an application is required then all local regulations, codes of practice and site rules must be observed. To ensure that the machine can operate in a safe and reliable manner, additional equipment such as gas detection, exhaust spark arrestors, and intake (shut-off) valves may be required, dependent on local regulations or the degree of risk involved.

Air discharged from this machine may contain carbon monoxide or other contaminants which will cause serious injury or death. Do not breathe this air.

Compressed air can be dangerous if incorrectly handled. Before doing any work on the unit, ensure that all pressure is vented from the system and that the machine cannot be started accidentally.

Ensure that the machine is operating at the rated pressure and that the rated pressure is known to all relevant personnel.

All air pressure equipment installed in or connected to the machine must have safe working pressure ratings of at least the machine safety valve rating.

If more than one compressor is connected to one common downstream plant, effective check valves and isolation valves must be fitted and controlled by work procedures, so that one machine cannot accidentally be pressurized or over pressurized by another.

Compressed air must not be used for a feed to any form of breathing apparatus or mask.

The discharged air contains a very small percentage of compressor lubricating oil and care should be taken to ensure that downstream equipment is compatible.

If the discharged air is to be ultimately released into a confined space, adequate ventilation must be provided.

When using compressed air, always use appropriate personal protective equipment.

All pressure containing parts, especially flexible hoses and their couplings, must be regularly inspected, be free from defects and be replaced according to the Manual instructions.

Avoid bodily contact with compressed air.

The safety valve located in the separator tank must be checked periodically for correct operation.

Never operate unit without first observing all safety warnings and carefully reading the operation and maintenance manual shipped from the factory with this machine.

Never operate the engine of this machine inside a building without adequate ventilation. Avoid breathing exhaust fumes when working on or near the machine. Do not alter or modify this machine.

A battery contains sulfuric acid and can give off gases which are corrosive and potentially explosive. Avoid contact with skin, eyes and clothing. In case of contact, flush area immediately with water.

Exercise extreme caution when using booster battery. To jump battery, connect ends of one booster cable to the positive (+) terminal of each battery. Connect one end of other cable to the negative (-) terminal of the booster battery and other end to a ground connection away from dead battery (to avoid a spark occurring near any explosive gases that may be present). After starting unit, always disconnect cables in reverse order.

Never operate unit without first observing all safety warnings and carefully reading the operation and maintenance manual shipped from the factory with this machine.

---

This machine may include such materials as oil, diesel fuel, antifreeze, brake fluid, oil/air filters and batteries which may require proper disposal when performing maintenance and service tasks. Contact local authorities for proper disposal of these materials.

A battery contains sulfuric acid and can give off gases which are corrosive and potentially explosive. Avoid contact with skin, eyes and clothing. In case of contact, flush area immediately with water.

High Pressure Air can cause serious injury or death. Relieve pressure before removing filler plugs/caps, fittings or covers.

Air pressure can remain trapped in air supply line which can result in serious injury or death. Always carefully vent air supply line at tool or vent valve before performing any service.

This machine produces loud noise with the doors open or service valve vented. Extended exposure to loud noise can cause hearing loss. Always wear hearing protection when doors are open or service valve is vented.

Never inspect or service unit without first disconnecting battery cable(s) to prevent accidental starting.

Do not remove the pressure cap from a HOT radiator. Allow radiator to cool down before removing pressure cap.

Do not use petroleum products (solvents or fuels) under high pressure as this can penetrate the skin and result in serious illness. wear eye protection while cleaning unit with compressed air to prevent debris from injuring eye(s).

Disconnected air hoses whip and can cause serious injury or death. Always attach a safety flow restrictor to each hose at the source of supply or branch line in accordance with OSHA Regulation 29CFR Section 1926.302(b).

Hot pressurized fluid can cause serious burns. Do not open radiator while hot.

Rotating fan blade can cause serious injury. Do not operate without guard in place.

Use care to avoid contacting hot surfaces (engine exhaust manifold and piping, air receiver and air discharge piping, etc.).

Ether is an extremely volatile, highly flammable gas. USE SPARINGLY! Do NOT use ETHER if unit has GLOW Plug starting aid. Engine damage will result.

Never allow the unit to sit stopped with pressure in the receiver-separator system. As a precaution, open the manual blowdown valve.

Never operate unit with guards, covers or screens removed. Keep hands, hair, clothing, tools, blow gun tips, etc. well away from moving parts.

Make sure wheels, tires and tow bar connectors are in safe operating condition and tow bar is properly connected before towing.

Whenever the machine is stopped, air will flow back into the compressor system from devices or systems downstream of the machine unless the service valve is closed. Install a check valve at the machine service valve to prevent reverse flow in the event of an unexpected shutdown when the service valve is open.

#### **Hazardous Substance Precaution**

The following substances are used in the manufacture of this machine and may be hazardous to health if used incorrectly.

**Precaution:** Avoid ingestion, skin contact and breathing fumes for the following substances: Antifreeze, Compressor Oil, Engine Lubricating Oil, Preservative Grease, Rust Preventative, Diesel Fuel and Battery Electrolyte.

The following substances may be produced during the operation of this machine and may be hazardous to health:

Avoid build-up of Engine Exhaust Fumes in confined spaces.

Avoid breathing Exhaust Fumes.

Avoid breathing Brake Lining Dust during maintenance.

## SAFETY LABELS

Look for these signs on machines shipped to international markets outside North America, which point out potential hazards to the safety of you and others. Read and understand thoroughly. Heed warnings and follow instructions. If you do not understand, inform you supervisor.



Corrosion risk



Hot Surface

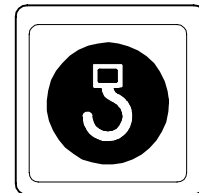

Lifting point

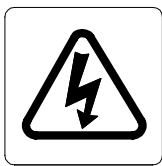

WARNING: Electrical shock risk.

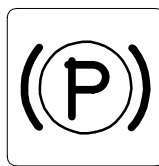

Parking Brake



No open flame

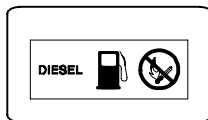

Diesel Fuel.  
No open flame.

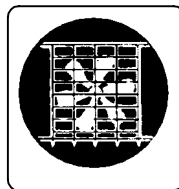

Do not operate the machine  
without guard being fitted.



Lifting point



WARNING - Flammable liquid.

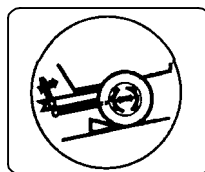

When parking use prop stand,  
handbrake and wheel chocks.

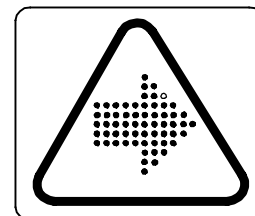

Air/gas flow or Air discharge.



WARNING - Hot and harmful exhaust gas.



Tie down point

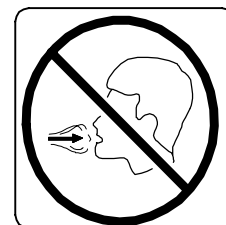

Do not breathe the compressed  
air from this machine.





Read the Operation and Maintenance manual before operation or maintenance of this machine is undertaken.

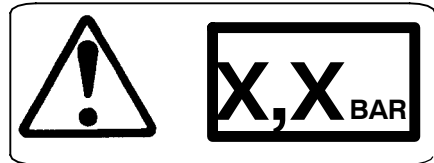

**WARNING - Maintain correct tire pressure.** (Refer to the *GENERAL INFORMATION* section of this manual).

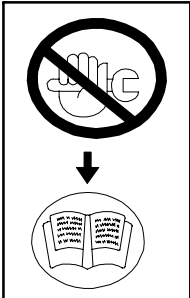

**WARNING:** Consult the operation and maintenance manual before performing any maintenance.



**Rough Service Designation  
Wet Location Operation**



**Do not stack**



**Do not use fork lift truck from this side**

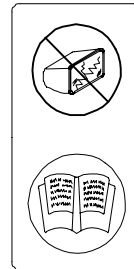

**Replace any cracked protective shield.**

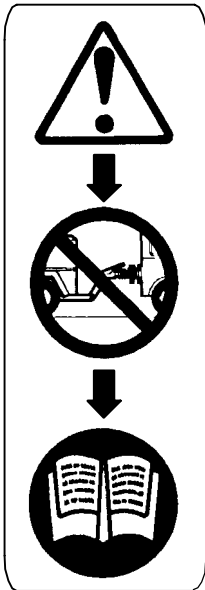

**WARNING - Before connecting the tow bar or when preparing to tow, consult the operation and maintenance manual.**

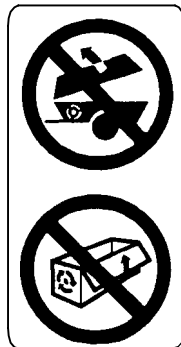

**Do not operate with the doors or enclosure open.**



**On (power).**



**Off (power).**



**Emergency stop.**

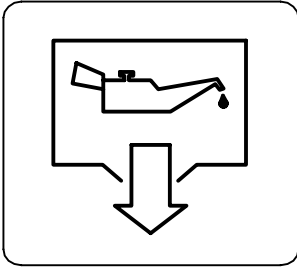

Oil Drain

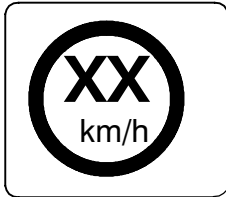

Do not exceed the speed limit.

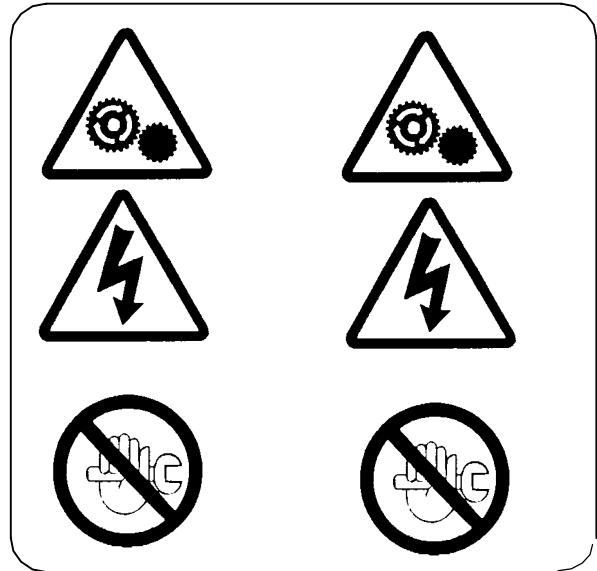

**WARNING** - Do not undertake any maintenance on this machine until the electrical supply is disconnected and the air pressure is totally relieved.

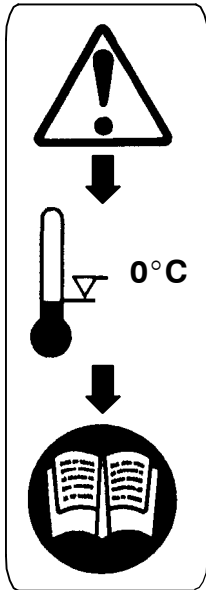

**WARNING** - For operating temperature below 0°C, consult the operation and maintenance manual.



Read the Operation and Maintenance manual before operation or maintenance of this machine is undertaken



Do not remove the Operating and Maintenance manual and manual holder from this machine.

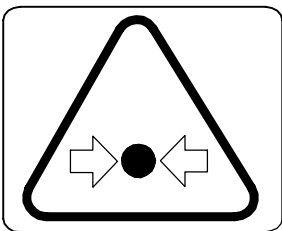

Pressurized vessel.



Use fork lift truck from this side only.

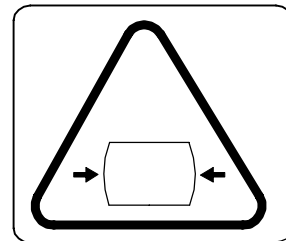

Pressurized component or system.

Look for these signs on machines shipped to markets in North America, which point out potential hazards to the safety of you and others. Read and understand thoroughly. Heed warnings and follow instructions. If you do not understand, inform your supervisor.



(Red Background)

Indicates the presence of a hazard which WILL cause serious injury, death or property damage, if ignored.



(Orange Background)

Indicates the presence of a hazard which CAN cause serious injury, death or property damage, if ignored.



(Yellow Background)

Indicates the presence of a hazard which WILL or can cause injury or property damage, if ignored.

**NOTICE**

(Blue Background)

Indicates important set-up, operating or maintenance information.

**Air discharged from this machine can contain carbon monoxide or other contaminants which will cause serious injury or death. Do not breathe this air.**

**Trapped air pressure. Can cause serious injury or death.**  
Close service valve and operate tool to vent trapped air before performing any service.

**Hot pressurized fluid. Can cause serious burns. Do not open radiator while hot.**

**High pressure air. Can cause serious injury or death.**  
Relieve pressure before removing filler plugs/ caps, fittings or covers.

## WARNING

**Improper operation of this equipment. CAN cause serious injury or death.**

Read Operator's Manual supplied with this machine before operation or servicing.

## WARNING

**Modification or alteration of this machine. CAN cause serious injury or death.**

Do NOT alter or modify this machine without the express written consent of the manufacturer.

## WARNING

**Collapsing jack stand. Will cause serious injury.**

Insert locking pin completely.

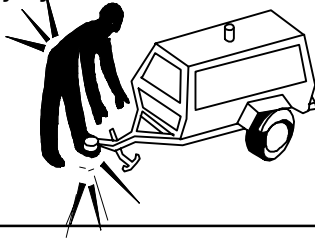

**Excessive towing speed. Can cause serious injury or death. Do NOT exceed 65 mph (104 km/hr)**

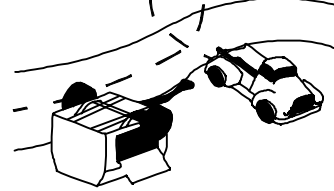

*For Highway Towable Units*

## WARNING

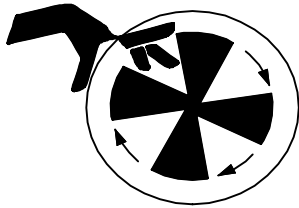

**Rotating Fan Blade. CAN cause serious injury.**

Do NOT operate with guard removed.

## WARNING

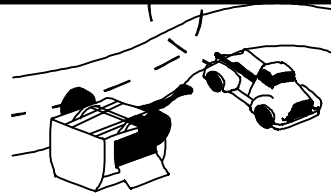

**Excessive Towing Speed. CAN cause serious injury or death.**

Do NOT Tow on Highway.  
Do NOT exceed 20 mph (32 km/h)

**For Non-Highway Towable Machines**

## WARNING

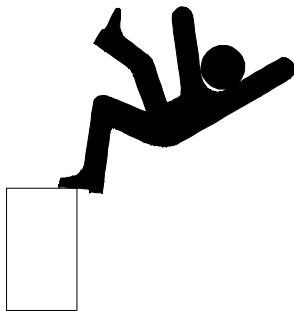

**Falling off machine. CAN cause serious injury or death.**

Access Lifting Bail from inside machine.

## WARNING

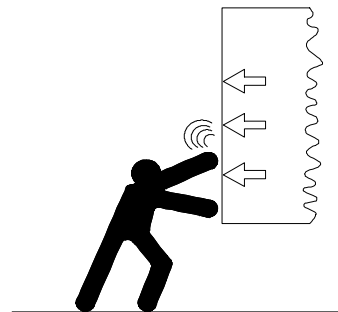

**Door under pressure CAN cause serious injury.**

Use both hands to open door when machine is running.

---

## WARNING

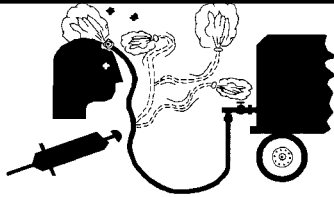

**Disconnected Air Hoses Whip. CAN cause serious injury or death.**

When using air tools attach safety device (OSHA Valve) at source of air supply for each tool.

## WARNING



**Combustible Gas. CAN cause serious burns, blindness or death.**

Keep sparks and open flames away from batteries.

## FREE SAFETY DECALS!

To promote communication of Safety Warnings on products manufactured by the Portable Compressor Division in Mocksville, N.C., Safety Decals are available **free** of charge. Safety decals are identified by the decal heading: **DANGER, WARNING or CAUTION.**

Decal part numbers are on the bottom of each decal and are also listed in the compressor's parts manual. Submit orders for Safety Decals to the Mocksville Parts Service Department. The no charge order should contain only Safety Decals. Help promote product safety! Assure that decals are present on the machines. Replace decals that are not readable.

---

## SECTION 2 - Warranty

Ingersoll-Rand, through its distributor, warrants that each item of equipment manufactured by it and delivered hereunder to the initial user will be free of defects in material and workmanship for a period of three (3) months from initial operation or six (6) months from the date of shipment to the initial user, whichever occurs first.

With respect to the following types of equipment, the warranty period enumerated below will apply in lieu of the foregoing warranty period.

- A. **Aftercoolers** - The earlier of nine (9) months from date of shipment to or six (6) months from start up by initial user.
  
- B. **Portable Compressors, Portable Generator Sets (GENSET) 8KW, 11KW, 20KVA thru 575KVA, Portable Light Towers and Air Dryers** - The earlier of twelve (12) months from shipment to or the accumulation of 2,000 hours of service by the initial user.  
**3.5KW thru 7.0KW and 10KW** - The earlier of twelve (12) months from shipment to or the accumulation of 2,000 hours of service by the initial user, whichever occurs first. Ingersoll-Rand will provide a new part or repaired part, at its election, in place of any part which is found to be defective in material or workmanship during the period described above. Labor cost to replace the part is the responsibility of the user.
  
- C. **Portable Compressor Air Ends** - The earlier of twenty-four (24) months from shipment to or the accumulation of 4,000 hours of service by the initial user. For Air Ends, the warranty against defects will include replacement of the complete Air End, provided the original Air End is returned assembled and unopened.
  
- C.1 **Portable Compressor Airend Limited Optional Warranty** - The earlier of sixty (60) months from shipment to or the accumulation of 10,000 hours of service. The optional warranty is limited to defects in rotors, housings, bearings and gears and provided all the following conditions are met:
  - 1. The original air end is returned assembled and unopened.
  - 2. Continued use of genuine Ingersoll-Rand parts, fluids, oil and filters.
  - 3. Maintenance is performed at prescribed intervals.**Oil-Free airends are fee-based and may require a maintenance agreement. Formal enrollment is required.**
  
- D. **Genset Generators 8KW, 11KW, 20KVA thru 575KVA** - The earlier of twenty-four (24) months from shipment to or the accumulation of 4,000 hours of service by the initial user.  
**3.5KW thru 7.0KW and 10KW** - The earlier of twelve (12) months from shipment to or the accumulation of 2,000 hours of service.
  
- E. **Portable Light Tower Generators**- The earlier of twelve (12) months from shipment to or the accumulation of 2,000 hours of service by the initial user. Light Source model only, the earlier of twenty-four (24) months from shipment to or the accumulation of 4,000 hours of service.
  
- F. **Ingersoll-Rand Engines** - The earlier of twenty-four (24) months from shipment to or the accumulation of 4,000 hours of service.

---

G. **Ingersoll-Rand Platinum Drive Train Warranty (Optional)** – Platinum drive train pertains to the Ingersoll-Rand Engine and Airend combination. The earlier of sixty (60) months from shipment to, or the accumulation of 10,000 hours of service. The starter, alternator, fuel injection system and all electrical components are excluded from the extended warranty. The airend seal and drive coupling are included in the warranty (airend drive belts are not included). The optional warranty is automatically available when meeting the following conditions:

1. The original airend is returned assembled and unopened.
2. Continued use of genuine Ingersoll-Rand parts, fluids, oil and filters.
3. Maintenance is performed at prescribed intervals.

It is the obligation of the user to provide verification that these conditions have been satisfied when submitting warranty claims.

F. **Spare Parts**– Six (6) months from date of shipment.

Ingersoll-Rand will provide a new part or repaired part, at its election, in place of any part which is found upon its inspection to be defective in material and workmanship during the period prescribed above. Such part will be repaired or replaced without charge to the initial user during normal working hours at the place of business of an Ingersoll-Rand distributor authorized to sell the type of equipment involved or other establishment authorized by Ingersoll-Rand. User must present proof of purchase at the time of exercising warranty.

The above warranties do not apply to failures occurring as a result of abuse; misuse, negligent repairs, corrosion, erosion and normal wear and tear, alterations or modifications made to the product without express written consent of Ingersoll-Rand; or failure to follow the recommended operating practices and maintenance procedures as provided in the product's operating and maintenance publications.

Accessories or equipment furnished by Ingersoll-Rand, but manufactured by others, including, but not limited to, engines, tires, batteries, engine electrical equipment, hydraulic transmissions, carriers, shall carry whatever warranty the manufacturers have conveyed to Ingersoll-Rand and which can be passed on to the initial user.

THIS WARRANTY IS IN LIEU OF ALL OTHER WARRANTIES EXPRESSED OR IMPLIED, (EXCEPT THAT OF TITLE), AND THERE ARE NO WARRANTIES OF MERCHANTABILITY OR OF FITNESS FOR A PARTICULAR PURPOSE.

# GENERAL WARRANTY INFORMATION

| GENERAL WARRANTY    |         |                 | Extended Coverage   |
|---------------------|---------|-----------------|---|
| Portable Compressor | Package | 1 year/2000 hrs |   |
|                     | Airend  | 2 yrs/4000 hrs  | 5 yrs/10,000 hrs<br>Limited warranty, major components<br>(refer to operator's manual). |

|   |           |                |      |
|---|-----------|----------------|------|
| Portable Genset 8kW, 11KW,<br>20KVA thru 575KVA | Package   | 1 yr/2000 hrs  | None |
|   | Generator | 2 yrs/4000 hrs | None |

|  |           |                             |      |
|--|-----------|-----------------------------|------|
| Portable Genset 3.5KW thru<br>7.0KW and 10KW | Package   | 1 yr/2000 hrs (parts only)  | None |
|  | Generator | 1 yrs/2000 hrs (parts only) | None |

|             |           |               |  |
|-------------|-----------|---------------|--|
| Light Tower | Package   | 1 yr/2000 hrs |  |
|             | Generator | 1 yr/2000 hrs | 2 years/4000 hours, for Lightsource<br>introduced 8/16/99. |

| ENGINES  |        |           |  |
|--|--------|-----------|--|
|  | Months | Hours     | Extended Coverage  |
| CATERPILLAR  | 12     | unlimited | Available at dealer  |
| CUMMINS  | 24     | 2000      | Major components 3 yrs/10,000 hrs<br>Available at dealer   |
| JOHN DEERE (in compressors)                              | 24     | 2000      | 5 yrs/5000 hrs using OEM fluids and filters with<br>\$250 deductible                                 |
| (in generators as of 1/1/01)                             | 24     | 2000      | 2 yrs/4000 hrs using IR fluids and filters   |
| DEUTZ  | 24     | 2000      | Available at dealer  |
| INGERSOLL-RAND   | 24     | 4000      | 5 yrs/10,000 hrs when using genuine Ingersoll-<br>Rand fluids and parts. Refer to operator's manual. |
| KUBOTA (North America only)                              | 24     | 2000      | Major components 36 mo/3000 hrs (parts only)   |
| (Western Europe & Oceania)                               | 24     | 2000      | None   |
| (Central & South America, Asia, Middle East &<br>Africa) | 12     | 1000      | None   |
| MITSUBISHI   | 24     | 2000      | 2 yrs/4000 hrs using IR fluids & filters   |
| VOLVO  | 24     | 2000      | 2 yrs/4000 hrs using ir fluids & filters   |
| HONDA  | 12     | unlimited | None   |
| VANGUARD   | 24     | unlimited | None   |

| PARTS          |        |          |            |
|----------------|--------|----------|------------|
|                | Months | Hours    | Coverage   |
| Ingersoll-Rand | 6      | No Limit | Parts Only |

| AIREND EXCHANGE |        |            |  |
|-----------------|--------|------------|--|
|                 | Months | Hours      | Extended Coverage                      |
| Airend          | 12     | 2000 hours | 2 yrs/4000 hrs - available from<br>IR. |

Note: Actual warranty times may change. Consult the manufacturer's warranty policy as shipped with each new product.



## Extended Limited Airend Warranty

Ingersoll-Rand Portable Compressor Division is pleased to announce the availability of extended limited airend warranty. Announcement of the extended warranty coincides with the introduction of PRO•TEC™ Compressor Fluid. PRO•TEC™ Compressor Fluid is an amber colored fluid specially formulated for Portable Compressors and is being provided as the factory filled fluid for all machines except 1 XHP650/900/1070 models.

All machines have the standard airend warranty - *The earlier of 24 months from shipment to, or the accumulation of 4000 hours of service.*

The warranty against defects will include replacement of the complete airend, provided the original airend is returned assembled and unopened.

The optional limited warranty is the earlier of 60 months from shipment to, or the accumulation of 10,000 hours of service. The optional warranty is limited to defects in major components (rotors, housings, gears, bearings), and is automatically available when the following three conditions are met:

1. The original airend is returned assembled and unopened.
2. Submissions of proof that Ingersoll-Rand fluid, filters and separators have been used. Refer to the Operation and Parts manual for the correct fluids, filters and separator elements required.
3. Submission of proof that maintenance intervals have been followed.

| <b>WARRANTY</b> | <b>TIME</b>             | <b>*BARE AIREND</b>         | <b>** AIREND COMPONENTS</b> |
|-----------------|-------------------------|-----------------------------|-----------------------------|
| <b>STANDARD</b> | <b>2 yrs/4000 hrs</b>   | <b>100% parts and labor</b> | <b>100% parts and labor</b> |
| <b>OPTIONAL</b> | <b>5 yrs/10,000 hrs</b> | <b>100% parts and labor</b> | <b>0%</b>                   |

\* Bare Airend - pertains to major airend parts (rotors, housings, gears and bearings).

\*\* Airend Components - pertains to auxiliary attachments to the bare airend (drive coupling, seals, pumps, valves, tubes, hoses, fittings and filter housing).

**PRO•TEC™ and XHP505 Compressor Fluids are available from the Mocksville Product Support department by calling 1-800-633-5206.**

<sup>1</sup> XHP650/900/1070 will continue to use XHP505 and will have the extended warranty when above conditions are met.

---

# ***WARRANTY REGISTRATION***

## **Complete Machine Registration**

Machines shipped to locations within the United States do not require a warranty registration unless the machine status changes (i.e. change of ownership).

Machines shipped outside the United States require notification be made to initiate the machine warranty.



**Fill out the Warranty Registration Form in this section, keep a copy for your records and mail form to:**

Ingersoll-Rand Company  
Portable Compressor Division  
P.O. Box 868  
Mocksville, North Carolina 27028  
Attn: Warranty Department

**Note: Completion of this form validates the warranty.**

| <u>Selling Distributor</u> | <u>Servicing Distributor</u> | <b>WARRANTY REGISTRATION</b> |  |
|----------------------------|------------------------------|------------------------------|--|
| Name _____                 | Name _____                   | Owner/User Name _____        |  |
| Address _____              | Address _____                | Address _____                |  |
| City _____                 | City _____                   | City _____                   |  |
| County _____               | County _____                 | County _____                 |  |
| State _____                | State _____                  | State _____                  |  |
| Zip Code _____             | Zip Code _____               | Zip Code _____               |  |
| Telephone _____            | Telephone _____              | Telephone _____              |  |

**Complete the Applicable Blocks**  
**Owner/User Type of Business (check one only)**

|   |  |                                      |  |
|---|--|--------------------------------------|--|
| <input type="checkbox"/> Construction-Heavy<br>(highway, excavation, etc.)                  | <input type="checkbox"/> Asphalt Contractor                                | <input type="checkbox"/> Coal Mining | <input type="checkbox"/> Other Mining                                    |
| <input type="checkbox"/> Construction-Light<br>(carpentry, plumbing, pools,<br>mason, etc.) | <input type="checkbox"/> Government<br>(municipal, state,<br>county, etc.) | <input type="checkbox"/> Quarry      | <input type="checkbox"/> Shallow Oil & Gas                               |
| <input type="checkbox"/> Rental<br>(rental center, rental fleet, etc.)                      | <input type="checkbox"/> Building Contractor                               | <input type="checkbox"/> Waterwell   | <input type="checkbox"/> Utility Company<br>(gas, electric, water, etc.) |
| <input type="checkbox"/> Industrial (plant use)   | <input type="checkbox"/> Other<br>specify _____                            | <input type="checkbox"/> Exploration | <input type="checkbox"/> Utility Contractor                              |

|                   |                   |                   |                         |
|-------------------|-------------------|-------------------|-------------------------|
| <b>Model</b>      | <b>Unit S/N</b>   | <b>Engine S/N</b> | <b>Date Delivered</b>   |
|                   |                   |                   |                         |
| <b>Unit-Hours</b> | <b>Airend S/N</b> | <b>Truck S/N</b>  | <b>Truck Engine S/N</b> |
|                   |                   |                   |                         |

**SERVICING DISTRIBUTOR/USER ACKNOWLEDGEMENT**

1. The Purchaser has been instructed and/or has read the manual and understands proper preventative maintenance, general operation and safety precautions.
2. The warranty and limitation of liability has been reviewed and understood by the owner/user.
3. In the event that this unit is to be used within a nuclear facility, the owner/user shall notify Ingersoll-Rand of such use so that Ingersoll-Rand may arrange for appropriate nuclear liability protection from the owner-licensee of the facility.
4. Ingersoll-Rand reserves the right to make design changes or modifications of Ingersoll-Rand products at anytime without incurring any obligation to make similar changes or modifications on previously sold units.

---

*Attention: Warranty Department*

*Ingersoll-Rand Company  
Portable Compressor Division  
P.O. Box 868  
Mocksville, North Carolina 27028*

-----  
*fold*  
-----

---

# SECTION 3 - NOISE EMISSION

**This section pertains only to machines distributed within the United States.**

## **WARNING**

### **TAMPERING WITH NOISE CONTROL SYSTEM PROHIBITED**

Federal law prohibits the following acts or the causing thereof:

(1) The removal or rendering inoperative by any persons, other than for purposes of maintenance, repair, or replacement, of any device or element of design incorporated into any new compressor for the purpose of noise control prior to its sale or delivery to the ultimate purchaser or while it is in use; or (2) the use of the compressor after such device or element of design has been removed or rendered inoperative by any person.

Among those acts included in the prohibition against tampering are these:

4. Removal or rendering inoperative any of the following:
  - a. the engine exhaust system or parts thereof
  - b. the air intake system or parts thereof
  - c. enclosure or parts thereof
5. Removal of any of the following:
  - a. fan shroud
  - b. vibration mounts
  - c. sound absorption material
6. Operation of the compressor with any of the enclosure doors open.

### **Compressor Noise Emission Control Information**

A. The removal or rendering inoperative, other than for the purpose of maintenance, repair, or replacement of any noise control device or element of design incorporated into this compressor in compliance with the noise control act;

B. The use of this compressor after such device or element of design has been removed or rendered inoperative.

**Note: the above information applies only to units that are built in compliance with the U.S. Environmental Protection Agency.**

Ingersoll-Rand Company reserves the right to make changes or add improvements without notice and without incurring any obligation to make such changes or add such improvements to products sold previously.

The Purchaser is urged to include the above provisions in any agreement for any resale of this compressor.



# NOISE EMISSION CONTROL MAINTENANCE LOG

|                        |
|------------------------|
| COMPRESSOR MODEL _____ |
| SERIAL NO. _____       |
| USER UNIT NO. _____    |

|  |  |
|--|--|
| <b>UNIT IDENTIFICATION</b><br>Engine Make & Model: _____<br>Serial No.: _____<br>Purchaser or Owner: _____<br>Address: _____ | <b>DEALER OR DISTRIBUTOR FROM WHOM PURCHASED:</b><br>_____<br>_____<br>Date Purchased: _____ |
|--|--|

The Noise Control Act of 1972 (86 Stat. 1234) prohibits tampering with the noise control system of any compressor manufactured and sold under the above regulations, specifically the following acts or the causing thereof:

(1) the removal or rendering inoperative by any persons, other than for purposes of maintenance, repair, or replacement, of any device or element of design incorporated into new compressor for the purpose of noise control prior to its sale or delivery to the ultimate purchaser or while it is in use; or (2) the use of the compressor after such device or element of design has been removed or rendered inoperative by any person.

## NOISE EMISSION WARRANTY

The manufacturer warrants to the ultimate purchaser and each subsequent purchaser that this air compressor was designed, built and equipped to conform at the time of sale to the first retail purchaser, with all applicable U.S. EPA Noise Control Regulations.

This warranty is not limited to any particular part, component, or system of the air compressor. Defects in the design, assembly or in any part, component, or system of the compressor which, at the time of sale to the first retail purchaser, caused noise emissions to exceed Federal Standards are covered by this warranty for the life of the air compressor.

## INTRODUCTION

The unit for which this Maintenance Log is provided conforms to U.S. E.P.A. Regulations for Noise Emissions, applicable to Portable Air Compressors.

The purpose of this book is to provide (1) the Maintenance Performance Schedule for all required noise emission controls and (2) space so that the purchaser or owner can record what maintenance was done, by whom, where and when. The Maintenance Schedule and detailed instructions on the maintenance items are given on following page.

## MAINTENANCE SCHEDULE

| ITEM | AREA                        | PERIOD                |
|------|-----------------------------|-----------------------|
| A.   | Compressed Air Leaks        | As Detected           |
| B.   | Safety and Control Systems  | As Detected           |
| C.   | Acoustic Materials          | Daily                 |
| D.   | Fasteners                   | 100 hours             |
| E.   | Enclosure Panels            | 100 hours             |
| F.   | Air Intake & Engine Exhaust | 100 hours             |
| G.   | Cooling Systems             | 250 hours             |
| H.   | Isolation Mounts            | 250 hours             |
| I.   | Engine Operation            | See Operator's Manual |
| J.   | Fuels & Lubricants          | See Operator's Manual |

### A. Compressed Air Leaks

Correct all compressed air leaks during the first shut-down period after discovery. If severe enough to cause serious noise problems and efficiency loss, shut down immediately and correct the leak(s).

### B. Safety and Control Systems

Repair or replace all safety and control systems or circuits as malfunction occurs. No compressor should be operated with either system bypassed, disabled, or nonfunctional.

### C. Acoustic Materials

In daily inspections, observe these materials. Maintain all acoustic material as nearly as possible in its original condition. Repair or replace all sections that have: 1) sustained damage, 2) have partially separated from panels to which they were attached, 3) are missing, or have otherwise deteriorated due to severe operating or storage conditions.

### D. Fasteners

All fasteners such as hinges, nuts, bolts, clamps, screws, rivets, and latches should be inspected for looseness after each 100 hours of operation. They should be retightened, repaired, or if missing, replaced immediately to prevent subsequent damage and noise emission increase.

### E. Enclosure Panels

Enclosure panels should also be inspected at 100 hour operational intervals. All panels that are warped, punctured, torn, or otherwise deformed, such that their noise containment function is reduced, should be repaired or replaced before the next operation interval. Doors, access panels, and hatch closures especially, should be checked and adjusted at this time to insure continuous seating between gasket or acoustic material and the mating frame.

### F. Air Intake and Engine Exhaust

Engine and compressor air intake and engine exhaust systems should be inspected after each 100 hours of operation for loose, damaged, or deteriorated components. Repairs or replacements should be made before the next period of use.

### G. Cooling Systems

All components of the cooling system for engine water and compressor oil should be inspected every 250 hours of use. Any discrepancies found should be corrected before placing the unit back in operation. Unrestricted airflow over the radiator and oil cooler must be maintained at all times during operation.

### H. Isolation Mounts

Engine/airend isolation mounts should be inspected after each 250 hours of operation. Those mounts with cracks or splits in the molded rubber, or with bent or broken bolts due to operation or storage in severe environments, all should be replaced with equivalent parts.

### I. Engine Operation

Inspect and maintain engine condition and operation as recommended in the manuals supplied by the engine manufacturer.

### J. Fuels and Lubricants

Use only the types and grades of fuels and lubricants recommended in the Ingersoll-Rand Company and Engine Manufacturer's Operator and Maintenance Manuals.

**MAINTENANCE RECORD FOR NOISE EMISSION CONTROL AND EXTENDED WARRANTY**

| <b>ITEM NO.</b> | <b>DESCRIPTION OF WORK</b> | <b>HOURLY METER<br/>READING</b> | <b>MAINT/<br/>INSPECT DATE</b> | <b>LOCATION CITY/<br/>STATE</b> | <b>WORK DONE BY<br/>(NAME)</b> |
|-----------------|----------------------------|---------------------------------|--------------------------------|---------------------------------|--------------------------------|
|                 |                            |                                 |                                |                                 |                                |
|                 |                            |                                 |                                |                                 |                                |
|                 |                            |                                 |                                |                                 |                                |
|                 |                            |                                 |                                |                                 |                                |
|                 |                            |                                 |                                |                                 |                                |
|                 |                            |                                 |                                |                                 |                                |
|                 |                            |                                 |                                |                                 |                                |
|                 |                            |                                 |                                |                                 |                                |
|                 |                            |                                 |                                |                                 |                                |
|                 |                            |                                 |                                |                                 |                                |
|                 |                            |                                 |                                |                                 |                                |
|                 |                            |                                 |                                |                                 |                                |
|                 |                            |                                 |                                |                                 |                                |
|                 |                            |                                 |                                |                                 |                                |
|                 |                            |                                 |                                |                                 |                                |
|                 |                            |                                 |                                |                                 |                                |
|                 |                            |                                 |                                |                                 |                                |
|                 |                            |                                 |                                |                                 |                                |
|                 |                            |                                 |                                |                                 |                                |
|                 |                            |                                 |                                |                                 |                                |
|                 |                            |                                 |                                |                                 |                                |
|                 |                            |                                 |                                |                                 |                                |
|                 |                            |                                 |                                |                                 |                                |
|                 |                            |                                 |                                |                                 |                                |
|                 |                            |                                 |                                |                                 |                                |
|                 |                            |                                 |                                |                                 |                                |
|                 |                            |                                 |                                |                                 |                                |
|                 |                            |                                 |                                |                                 |                                |
|                 |                            |                                 |                                |                                 |                                |
|                 |                            |                                 |                                |                                 |                                |
|                 |                            |                                 |                                |                                 |                                |
|                 |                            |                                 |                                |                                 |                                |
|                 |                            |                                 |                                |                                 |                                |
|                 |                            |                                 |                                |                                 |                                |
|                 |                            |                                 |                                |                                 |                                |
|                 |                            |                                 |                                |                                 |                                |
|                 |                            |                                 |                                |                                 |                                |
|                 |                            |                                 |                                |                                 |                                |
|                 |                            |                                 |                                |                                 |                                |
|                 |                            |                                 |                                |                                 |                                |
|                 |                            |                                 |                                |                                 |                                |
|                 |                            |                                 |                                |                                 |                                |
|                 |                            |                                 |                                |                                 |                                |
|                 |                            |                                 |                                |                                 |                                |
|                 |                            |                                 |                                |                                 |                                |
|                 |                            |                                 |                                |                                 |                                |
|                 |                            |                                 |                                |                                 |                                |
|                 |                            |                                 |                                |                                 |                                |
|                 |                            |                                 |                                |                                 |                                |
|                 |                            |                                 |                                |                                 |                                |
|                 |                            |                                 |                                |                                 |                                |
|                 |                            |                                 |                                |                                 |                                |



# SECTION 4 - GENERAL DATA

| UNIT MODEL                      | HP600WJD  | XP750WJD  | HP750WJD  | XP825WJD  |
|---------------------------------|-----------|-----------|-----------|-----------|
| Air Delivery – cfm (litres/sec) | 600 (285) | 750 (355) | 750 (355) | 825 (390) |
| Engine Speed – RPM (Full Load)  | 2100      | 2100      | 2000      | 2000      |
| – RPM (No Load)                 | 1400      | 1400      | 1400      | 1400      |

## COMPRESSOR

|                                      |            |            |            |            |
|--------------------------------------|------------|------------|------------|------------|
| Rated Operating Pressure – psi (kpa) | 150 (1050) | 125 (875)  | 150 (1050) | 125 (875)  |
| Safety Valve Setting – psi (kPa)     | 200 (1400) | 175 (1225) | 200 (1400) | 175 (1225) |

## ENGINE (Diesel)

|                   |            |       |       |       |
|-------------------|------------|-------|-------|-------|
| Manufacturer      | John Deere |       |       |       |
| Model             | 6076A      | 6076A | 6081A | 6081A |
| Electrical System | 24 VDC     |       |       |       |

## FLUID CAPACITIES

|                                |         |      |      |           |
|--------------------------------|---------|------|------|-----------|
| Compressor Lubricant           | 16 gal. |      |      |           |
| Engine Lube (including filter) | 5.9     | 5.9  | 8.4  | 8.4 gal.  |
| Engine Coolant                 | 7.0     | 7.0  | 9.5  | 9.5 gal.  |
| Fuel Tank                      | 86.5    | 86.5 | 99.5 | 99.5 gal. |

## UNITS MEASUREMENTS/WEIGHTS

|                                  |             |      |      |      |
|----------------------------------|-------------|------|------|------|
| Overall Length                   | 191 inches  |      |      |      |
| Overall Height                   | 88.6 inches |      |      |      |
| Overall Width                    | 85.2 inches |      |      |      |
| Net Weight (less fuel) pounds    | 6900        | 6900 | 7050 | 7050 |
| Gross Weight (all fluids) pounds | 7500        | 7500 | 7850 | 7850 |

## RUNNING GEAR

|                           |             |  |  |  |
|---------------------------|-------------|--|--|--|
| Tire Size                 | 8.00 – 16.5 |  |  |  |
| Inflation Pressure (Cold) | 60 psi      |  |  |  |
| Towing Speed (Maximum)    | 50 mph      |  |  |  |

**CAUTION: Any departure from the specifications may make this equipment unsafe.**

---

# SECTION 5 - OPERATION

## WARNING

Do not climb on top of unit. The lifting eye can be reached through the roof door **ONLY** from **INSIDE** of the unit.

### TOWING

#### Steerable Axle Units

Do not tow this unit in excess of 20mph (32km/hr). Use a tow vehicle whose towing capacity is greater than the gross weight of this unit.

#### Tandem Axle Units

These units are designed to be highway towable. Do NOT exceed 65 mph towing speed.

- When lifting or lowering drawbar, always grasp drawbar firmly and stand to one side.
- Ensure that the tires, wheels and running gear are in good condition and secure.

### SETTING - UP (ALL UNITS)

- Place the unit in an open, well-ventilated area. Position as level as possible. The design of these units permits a 15 degree sidewise limit on out-of-level operation.
  - When the unit is to be operated out-of-level it is important: (1) to keep the engine crankcase oil level near the high level mark (with the unit level), and (2) to have the compressor oil level gauge show no more than mid-scale (with the unit running at full load). Do not overfill either the engine crankcase or the compressor lubricating oil system.

## CAUTION

Do not connect the air discharge on this unit onto a common header with any other unit of any description, or any other source of compressed air, without first making sure a check-valve is used between the header and the unit. If this unit is connected in parallel with another unit of higher discharge pressure and capacity, a safety hazard could occur in a back-flow condition.

## WARNING

Hot pressurized fluid can cause severe burns. Do not open radiator while hot.

- Check engine coolant level by removing the radiator top cap and looking for coolant in the filler neck of the radiator. Add coolant as required. Insure that radiator cap is installed properly and tightened. Note: this machine will not allow engine starting if engine coolant is low.

**NOTICE:** If the appropriate mixture of antifreeze is not used during freezing temperatures, failure to drain the engine may cause costly engine damage. Never use water only as corrosion inhibitors are required in engine coolant fluid.

## CAUTION

No smoking, sparks, or open flame near fuel.

- Check the fuel level. Add only CLEAN DIESEL fuel for maximum service from the engine. Refer to the engine Operator's Manual for fuel specifications.

**NOTICE:** To minimize condensation (water) in the fuel tank, it is recommended to fill the tank at the end of each day.

## WARNING

This machine produces loud noise with doors open. Extended exposure to loud noise can cause hearing loss. Wear hearing protection when doors or valve (s) are open.

- Close the side doors to maintain a cooling air path and to avoid recirculation of hot air. This will maximize the life of the engine and compressor and protect the hearing of surrounding personnel.
- Be sure no one is IN or ON the compressor unit.

---

## **STARTING -**

- Flip the POWER switch to “ON”. All diagnostics lamps will light (glow for two (2) seconds. Then all lamps should go off except for ALTERNATOR NOT CHARGING and LOW ENGINE OIL PRESSURE.

- Press and hold the BYPASS button for ten (10) to fifteen (15) seconds. This operates the 24 volt compressor which pressurizes the inlet valve air cylinder and holds the inlet valve closed for easier starting.

- Press both the START and the BYPASS buttons to crank the engine. **DO NOT OPERATE THE STARTER MOTOR FOR MORE THAN TEN (10) SECONDS WITHOUT ALLOWING AT LEAST ONE MINUTE COOLING TIME BETWEEN START ATTEMPTS.**

### **CAUTION**

**Ether is an extremely volatile, highly flammable gas. Use sparingly! If too much is injected, the uncontrolled explosion may result in costly damage to the engine.**

- In cold weather, as required, press the ETHER INJECT button once or twice only, while the engine is cranking. This injects a measured amount of ether to the engine.

- Release the START button when the engine starts and sustains running. If the engine does not start after a couple of attempts, refer to Trouble Shooting Section.

- Release BYPASS button when the engine speed reaches 1000 rpm. The engine oil pressure should be above 20 psi.

If the engine oil pressure does not rise within five (5) seconds, stop the unit and refer to Engine Operator's Manual.

### **WARNING**

All DIAGNOSTIC lamps should be off. If not, stop the machine and investigate.

- Watch the gauges while the unit warms up for five (5) to ten (10) minutes or until the coolant temperature reaches 140° F (60° C).

- Push the SERVICE AIR button. The engine should go to full speed and the discharge pressure rise to slightly over rated pressure. If there is no air being consumed, the compressor will unload (intake should be throttled or closed) and the engine speed drop to the no load speed.

- Compressor is now ready to furnish air when the service valve is opened.

- Close air service valve (s).

- Allow the unit to run at “no load” for 3 to 5 minutes to reduce the engine temperatures

- Flip all toggle switches to “Off”.

### **NOTICE**

**Once the engine stops, the automatic blowdown valve will begin to relieve all pressure from the receiver-separator system.**

### **CAUTION**

**Never allow the unit to sit stopped with pressure in the receiver-separator system. As a precaution, open the service valve.**

### **WARNING**

**Even after pressure is relieved from the receiver-separator system, any air supply line from the compressor to a tool or machine could remain under pressure and cause very serious personal injury or death.**

**After the compressor stops, carefully open a valve at any tool or machine to exhaust the pressure in any line prior to removal or servicing.**

### **NOTICE**

**Do NOT wire around or bypass a shutdown sensor or switch.**

All units in this family of machines are protected by five (5) sensors or switches at the following locations:

(1) High engine COOLANT temperature in the engine.

- 
- (2) Low engine oil pressure, in the engine.
  - (3) Low Fuel Level. (First, the light on the control panel will come on as a warning).

#### **High Discharge AIR Temperature**

- (4) At the airend outlet.
- (5) In the side cover of the separator tank.

All sensors and additional low oil pressure switch (mentioned above) will automatically reset when the problem condition is corrected.

#### **UNITS RATED BELOW 200 PSI (1400 kPa)**

These units include an additional low oil pressure switch in the supply line to the airend bearings.

#### **AUTOMATIC SHUTDOWN / DIAGNOSTICS**

Should any of these problem situations occur, the unit will automatically shutdown and stop. BEFORE re-starting the unit or flipping the POWER switch to "Off", check the DIAGNOSTICS area on the instrument panel.

The upper four (4) lamps are electronically "latched" to only respond to the first or primary signal for a shutdown. In other words, if the automatic shutdown is the result of one of these four problems, only that particular problem lamp will be lit. And the lamp will remain lit as long as the batteries provide power.

Refer to OPERATING CONTROLS AND INSTRUMENTS, for the various problem signal criteria (°F, psi, etc.). The indicated problem area should be inspected for a physical cause (low fluid, broken fan belt, evidence of excessive heat, etc.) and corrections made.

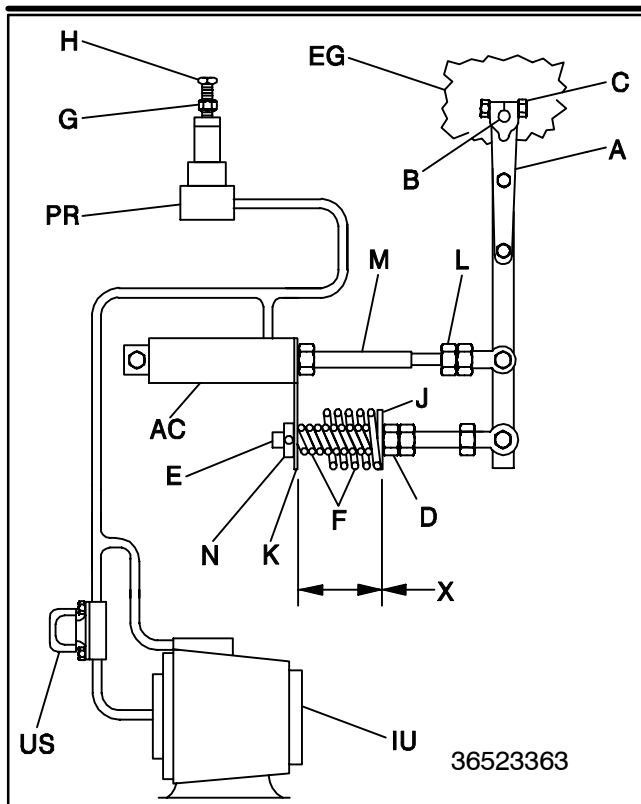

Normally, regulation requires no adjusting, but if proper adjustment is lost, proceed as follows:

#### Before Starting Unit -

1. At engine governor, (EG), check the position of throttle arm (A) on governor shaft (B). This is done by loosening nut (C) that clamps the throttle arm (A) to the shaft (B). Rotate shaft (B) counterclockwise as far as possible. Rotate throttle arm until it is vertical. Tighten nut (C).
2. Adjust jam nut (D) on throttle spring rod (E) to fully relieve tension on two compression springs (F).
3. Atop separator cover at pressure regulator (PR) loosen locknut (G) counterclockwise. Turn adjustment screw counterclockwise on full turn.

#### After Starting Unit -

4. Allow unit to warm up, then push "Service Air" button on control panel.
5. Open and adjust service valve on outside of the unit to obtain the rated operating pressure on the discharge pressure gauge.

Note: If the rated operating pressure cannot be maintained with engine at full load speed and rod (M) fully extended, turn regulator adjustment screw (H) clockwise until throttle arm (A) moves against governor stop.

6. Insure that pressure is maintained at rated pressure, then turn regulator adjustment screw (H) counterclockwise until throttle arm (A) just begins to move.

Note: Turning regulator adjustment screw (H) clockwise will raise pressure at full speed.

7. Adjust jam nut (D) on throttle spring rod (E) until distance "X" between spring mount (J) and rod guide (K) is 2.88 in. (73 mm).
8. Close service valve (engine will slow to no load or idle speed). Loosen jam nut (L) at air cylinder (AC) shaft. Rotate air cylinder shaft (M) to adjust speed to no load rpm. If unable to obtain no load rpm, loosen nut (C) and rotate throttle arm (A) as required. Moving throttle arm (A) clockwise increases idle speed. Tighten nut (C) and, if necessary, finely adjust idle speed by rotating air cylinder shaft (M). Then tighten jam nut (L).
9. If necessary, repeat steps 5 and 6.
10. At pressure regulator (PR) tighten lock nut (G).
11. Limit full load engine speed by adjusting the collar (N) on the end of the throttle spring rod (E).
12. To obtain maximum CFM at any pressure between 80 PSI (550 kPa) and the rated operating pressure, turn adjustment screw (H) of pressure regulator (PR) to obtain desired discharge pressure at full load engine speed. Always lock and protect pressure setting of adjusting screw (H) with locknut (G).
13. Ensure unloader solenoid (US) acts to hold pressure in inlet unloader (IU) after shut-down. After start-up, a pressure switch will open unloader solenoid (US).

---

# SECTION 6 - MAINTENANCE

## GENERAL

In addition to periodic inspections, many of the components in these units require periodic servicing to provide maximum output and performance. Servicing may consist of pre-operation and post-operation procedures to be performed by the operating or maintenance personnel. The primary function of preventive maintenance is to prevent failure, and consequently, the need for repair. Preventive maintenance is the easiest and the least expensive type of maintenance. Maintaining your unit and keeping it clean at all times will facilitate servicing.

## SCHEDULED MAINTENANCE

The maintenance schedule is based on normal operation of the unit. This page can be reproduced and used as a checklist by the service personnel. In the event unusual environmental operating conditions exist, the schedule should be adjusted accordingly.

## COMPRESSOR OIL LEVEL

The oil level is most consistent when the unit is RUNNING AT FULL LOAD and should be checked at this time. The optimum operating level is midway of the sight tube on the side of the receiver tank. See the decal beside the sight tube. If the oil level is not in the "OK" range, make appropriate corrections (Add or Drain). A totally filled sight tube in which the level is not visible indicates an over-full condition and requires that oil be drained.

## AIR CLEANER

This unit is equipped with an AIR FILTERS RESTRICTED lamp on the instrument panel, covering both the engine and the compressor.

This should be checked daily during operation. If the lamp glows (red) with the unit operating at full speed, servicing of the cleaner element is necessary. Also weekly squeeze the rubber valve (pre-cleaner dirt dump) on each air cleaner housing to ensure that they are not clogged.

**NOTE:** Holes or cracks downstream of the air cleaner housing will cause the restriction indicators to be ineffective.

The air filters restricted sensor will automatically reset after the main power switch is flipped to "OFF."

To service the air cleaners on all units proceed as follows:

1. Loosen outer wing nut and remove with outer element. Inspect red window on special inner wing nut to find small dot. If dot is not visible, remove cotter pin and special wing nut and inner (safety) element.
2. Inspect air cleaner housing for any condition that might cause a leak and correct as necessary.
3. Wipe inside of air cleaner housing with a clean, damp cloth to remove any dirt accumulation, especially in the area where the element seals against the housing.
4. Inspect element by placing a bright light inside and rotating slowly. If any holes or tears are found in the paper, discard this element. If no ruptures are found, the element can be cleaned by one of the following procedures.
5. If a new air filter element is to be used check it closely for shipping damage. To reset the signal indicator in the special wing nut, apply suction to the red window.
6. Install cleaned or new elements in the reverse order to the above. Tighten wing nuts firmly and replace cotter pin.
7. Inspect to ensure that the end cap seals tightly 360 degrees around the air cleaner body.

In the event that the filter element must be reused immediately, compressed air cleaning (as follows) is recommended since the element must be thoroughly dry.

Direct compressed air through the element in the direction opposite to the normal air flow through the element. Move the nozzle up and down while rotating the element. Be sure to keep the nozzle at least one inch (25.4 mm) from the pleated paper.

---

## NOTICE

To prevent damage to the element, never exceed a maximum air pressure of 100 psi (700 kPa).

In the event the element is contaminated with dry dirt, oil or greasy dirt deposits, and a new element is not available, cleaning can be accomplished by washing, using the air cleaner element manufacturer's recommendations.

## NOTICE

**It is highly recommended that new replacement elements be installed in the unit immediately in order that the unit be returned to service in the shortest possible time. In this manner the elements just removed for cleaning can be washed and stored as future replacement elements.**

In addition, the air cleaner system (housing and piping) should be inspected every month for any leakage paths or inlet obstructions. Make sure the air cleaner mounting bolts and clamps are tight. Check the air cleaner housing for dents or damage which could lead to a leak. Inspect the air transfer tubing from the air cleaner to the compressor and the engine for holes.

Make sure that all clamps and flange joints are tight.

### GAUGES

The instruments or gauges are essential for safety, maximum productivity and long service life of the machine. Inspect the gauges and test any diagnostic lamps prior to start-up. During operation observe the gauges and any lamps for proper functioning. Refer to Operating Controls, for the normal readings.

### FUEL TANK

This unit is equipped with dual tanks that can be filled from either side. Using clean fuel in the fuel tanks is vitally important and every precaution should be taken to ensure that only clean fuel is either poured or pumped into the tank.

When filling the fuel tank on this unit, by methods other than a pump and hose, use a CLEAN non-metallic funnel.

Every six months the drain plugs should be removed from the tanks so that any sediment or accumulated condensate may be drained. When replacing the drain plugs, make sure they are tightened securely.

### BATTERY

Heavy-duty, diesel cranking type batteries were installed at the factory and these should be inspected weekly. Keep the battery posts-to-cable connections clean, tight and lightly coated with a grease. Also the electrolyte level in each cell should cover the top of the plates. If necessary, top-up with clean distilled water.

### TIRES

A weekly inspection is recommended. Tires that have cuts or cracks or little tread should be repaired or replaced. Monthly check the wheel lug nuts for tightness.

The high discharge air temperature switch will require approximately 248°F (120° C) to actuate. The engine coolant temperature switch will require approximately 210° F (99° C) to actuate. Replace any defective switch before continuing to operate the unit.

A low oil pressure switch may be tested by removing it and connecting it to a source of controlled pressure while monitoring an ohmmeter connected to the switch terminals. As pressure is applied slowly from the controlled source, the switch should close at 12 psi (.84 kgf per cm<sup>2</sup>) and show continuity through the contacts.

---

## RADIATOR

### **WARNING**

As the pressure is slowly decreased to 8 psi (0.56 kgf per cm<sup>2</sup>) the contacts should open and the ohmmeter should show lack of continuity (infinite ohms) through the contacts. Replace a defective switch before continuing to operate the unit.

### COMPRESSOR OIL COOLER

The compressor lubricating and cooling oil is cooled by means of the fin and tube-type oil cooler, located beside the radiator. The lubricating and cooling oil, flowing internally through the core section, is cooled by the air stream from the cooling fan flowing past the core section. When grease, oil and dirt accumulate on the exterior surfaces of the oil cooler, its efficiency is impaired.

Each month it is recommended that the oil cooler be cleaned by directing compressed air which contains a nonflammable safety solvent through the core of the oil cooler. This should remove the accumulation of grease, oil and dirt from the exterior surfaces of the oil cooler core so that the entire cooling area can transmit the heat of the lubricating and cooling oil to the air stream.

In the event foreign deposits, such as sludge and lacquer, accumulate in the oil cooler to the extent that its cooling efficiency is impaired, a resulting high discharge air temperature is likely to occur, causing shut down of the unit. To correct this situation it will be necessary to clean it using a cleaning compound in accordance with the manufacturer's recommendations. Use only a dependable cleaning compound. This is of prime importance because different cleaners vary in concentration and chemical composition. After completing the cleaning procedure, the oil cooler must be flushed before returning to service.

**Do not remove the cap from a HOT engine radiator. The sudden release of pressure from a heated cooling system can result in a loss of coolant and possible severe personal injury.**

The engine cooling system is filled at the factory with a 50/50 mixture of water and ethylene glycol. This permanent type antifreeze contains rust inhibitors and provides protection to -35° F (-37°C). The use of such a mixture is recommended for both summer and winter operation. When using water alone, be sure to add a reputable brand of rust inhibitor to prevent internal corrosion.

It is recommended to test the freezing protection of the coolant every six months or prior to freezing temperatures. Replenish with a fresh mixture every twelve months. A drain for the system is located in the bottom radiator tank. An alternate method would be to disconnect a bottom radiator hose.

Each month, inspect the radiator exterior for obstructions (dirt, bugs, etc.). If present, blow water or compressed air containing a nonflammable solvent between the fins in a direction opposite the normal air flow. Should the radiator be clogged internally, standard automotive practices should be followed.

### HOSES

Each month it is recommended that all of the intake lines to and from the air cleaners, the engine cooling system hoses and all of the flexible hoses used for air, oil, and fuel be inspected.

To ensure freedom from air leaks, all rubber hose joints and the screw-type hose clamps must be absolutely tight. Regular inspection of these connections for wear or deterioration is a definite "must" if regulator servicing of the air cleaners is not to prove futile.

Premature wear of both the engine and compressor is ASSURED whenever dust-laden air is permitted to enter the engine's combustion chamber or the compressor intake practically unfiltered.



---

The flexible hoses used in the fuel, oil and air lines on these units are primarily used for their ability to accommodate relative movement between components. It is extremely important they be periodically inspected for wear and deterioration. Clamps are used to prevent hose cover abrasion through vibration. This abrasion may occur when two hose lines cross, or when a hose line rubs against a fixed point; therefore, it is necessary that all clamps be replaced if missing. It is also important the operator does not use the hoses as convenient hand hold or steps. Such use can cause early cover wear and hose failure.

### NOTICE

**Piping systems operating at less than 150 psi (1050 kPa) may use a special nylon tubing. The associated fittings are also of a special “push-in” design. If so, features are as follows:**

Pulling on the tubing will cause the inner sleeve to withdraw and compress, thus tightening the connection. The tubing can be withdrawn only while holding the sleeve against the fitting. The tubing can be removed and replaced numerous times without losing its sealing ability.

To install the nylon tubing, make a mark (with tape or grease pencil) approximately 7/8 inch from the end of the tubing. Insert the tubing into the sleeve and “push-in” past the first resistance to the bottom. The mark should be approximately 1/16 inch from the sleeve, for the 3/8 inch O.D. tubing; 1/8 inch for the 0.25 inch O.D. tubing. This will ensure that the tubing is fully engaged in the sealing mechanism.

### COMPRESSOR OIL FILTERS

The compressor lubrication and cooling oil system includes dual spin-on, throw away type oil filters, each with an internal bypass valve. With a clean, new filter element, all of the oil flows through the full element area, from the outside/inside. As each element becomes contaminated with dirt, a pressure differential is created in the filter housing between the oil inlet and outlet ports. As this differential approaches 25 psi (175 kPa), the bypass valve starts to open, thus permitting a small quantity of oil to bypass the filter. As the contaminants continue to build up, more and more of the oil bypasses the filter media itself.

This does not provide any filtration but does allow a maximum flow of compressor lubricating and cooling oil to preclude any possible damage from loss of oil. Also the design of the filter prevents any washing-off of any dirt during oil bypassing.

### NOTICE

**The oil filter must be replaced every 500 hours of operation. On new or overhauled units, replace the element after the first 50 and 150 hours of operation; thereafter, service the oil filter every 500 hours.**

To service the oil filters it will first be necessary to shut the unit down. Wipe off any external dirt and oil from the exterior of the filter to minimize any contamination from entering the lubrication system.

### **WARNING**

**High pressure air can cause severe injury or death from hot oil and flying parts. Always relieve pressure before removing caps, plugs, covers or other parts from pressurized air system.**

1. Open the service air valve(s) to ensure that system is relieved of all pressure. Close the valve(s).
2. Turn the spin-on filter element counterclockwise to remove it from the filter housing. Inspect the filter element and then discard.

---

## NOTICE

**If there is any indication of formation of varnishes, shellacs or lacquers on the oil filter element, it is a warning the compressor lubricating oil has improper characteristics and should be immediately changed.**

3. Inspect filter gasket contact area for cleanliness and damage. Clean or repair as necessary.
4. Install new filter by turning element clockwise until gasket makes initial contact. Tighten an additional 1/2 to 3/4 turn.
5. Start unit and allow to build up to rated pressure. Check for leaks before placing unit back into service.

## FASTENERS

Visually check entire unit in regard to bolts, nuts and screws being properly secured. Spot check several capscrews and nuts for proper torque. If any are found loose, a more thorough inspection must be made. Take corrective action.

## COMPRESSOR OIL

The lubricating and cooling oil must be replaced every 1000 hours of operation or six (6) months, whichever comes first.

## RUNNING GEAR

Every month or 500 miles, tighten the wheel lug nuts to 85 - 95 lbs.-ft. Every six months the wheel bearings, grease seals and axle spindles should be inspected for damage (corrosion, etc.) or excessive wear. Replace any damaged or worn parts. Repack wheel bearings. Use a wheel bearing grease conforming to specification MIL-G-10924 and suitable for all ambient temperatures.

Grease can be replaced in a wheel bearing using a special fixture or by hand as follows.

Before installing bearing, place a light coat of grease on the bearing cups which are pressed in the hub.

Place a spoonful of grease in the palm of one hand and take the bearing in the other hand. Push a segment of the wider end of the bearing down into the outer edge of the grease pile closest to the thumb. Keep lifting and pushing the bearing down into the edge of the grease pile until grease oozes out both from the top and from between the rollers. Then rotate the bearing to repeat this operation on the next segment. Keep doing this until you have the entire bearing completely filled with grease.

## NOTICE

**Excessive grease in the hub or grease cap serves no purpose due to the fact that there is no way to force the grease into the bearing. The manufacturer's standard procedure is to thoroughly pack the inner and outer bearing with grease and then to apply only a very small amount of grease into the grease cap.**

If bearing adjustment is required or the hub has been removed for any reason, the following procedure must be followed to ensure a correct bearing adjustment of 0.001 to .012 free play.

1. While rotating hub slowly to seat the bearings, tighten spindle nut to approximately 15 lbs.-ft. Grasp the tire at the top and bottom and rock, in and out. There should be no evidence of looseness (free play) at the bearing.
2. Loosen nut to remove preload torque. Do not rotate hub.
3. Finger tighten nut until just snug. Loosen nut until the first nut castellation lines up with cotter pin hole in spindle. Insert cotter pin.
4. Ensure a definite but minimal amount of free play by rocking the tire.
5. Bend over cotter pin legs to secure nut and clear grease cap.
6. Nut should be free to move with only restraint being the cotter pin.

---

## RECEIVER-SEPARATOR SYSTEMS

### **WARNING**

**High pressure air can cause severe injury or death from hot oil and flying parts. Always relieve pressure before removing caps, plugs, covers or other parts from pressurized air system.**

**\* Open service valve at end of machine.**

**\* Ensure pressure is relieved, with BOTH:**

- Discharge air pressure gauge reads zero (0).
- No air discharging from service valve.

\* When draining oil, remove and replace (make tight) plug at bottom of separator tank.

\* When adding oil, remove and replace (make tight) plug on side of separator tank.

In the compressor lubricating and cooling system, separation of the oil from the compressed air takes place in the receiver-separator tank. As the compressed air enters the tank, the change in velocity and direction drop out most of the oil from the air.

Additional separation takes place in the oil separator element which is located in the top of the tank.

Any oil accumulation in this separator element is continuously drained off by means of a scavenge tube which returns the accumulated oil to the system.

The life of the oil separator element is dependent upon the operating environment (soot, dust, etc.) and should be replaced every twelve months or 2000 hours. To replace the element proceed as follows:

a. Ensure the tank pressure is zero.

- b. Disconnect the hose from the scavenge tube.
- c. Remove scavenge tube from tank cover.
- d. Disconnect service line from cover.
- e. Remove (8) cover mounting screws.
- f. Remove cover, element and inner shell.
- g. Remove any gasket material left on cover or tank.
- h. Install new gasket, inner shell and new element.

### **NOTICE**

**Do not remove staples from the element/gasket connection.**

\*Place a straightedge across top of element and measure from bottom of straightedge to bottom of element (See Fig. 4.1).

\*Replace scavenge tube in cover (cover is still off of tank).

\*Measure from bottom of cover to end of scavenge tube (See Fig. 4.2). Measurement should be from 1/8" to 1/4" less than the element measurement. If not, cut to size.

\*Remove scavenge tube.

\*Reposition cover (use care not to damage gaskets).

\*Replace cover mounting screws: tighten in a crisscross pattern to recommended torque value.

\*Reconnect service line. Replace scavenge tube. Reconnect hose.

\*Close service valve. Start unit and look for leaks.

When replacing the element, the scavenge lines, orifice, filter, and check valve should be thoroughly cleaned and the oil changed.

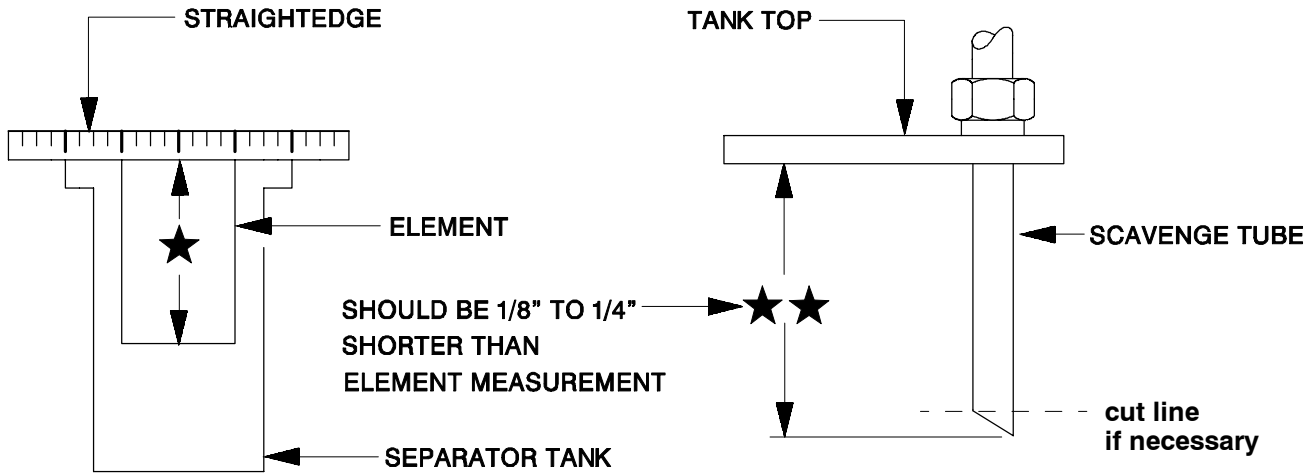

## SCAVENGE LINE

### WARNING

High pressure air can cause severe injury or death from hot oil and flying parts. Always relieve pressure before removing caps, plugs, covers or other parts from pressurized air system.

The scavenge line originates at the receiver-separator tank cover and terminates at the compressor aircend.

Once a year or every 2000 hours of operation, whichever comes first, remove this line, thoroughly clean, then reassemble.

## NOTICE

Excessive oil carry-over may be caused by an oil-logged separator element. Do not replace element without first performing the following maintenance procedure:

1. Check oil level. Maintain as indicated earlier in this section.
2. Thoroughly clean scavenge line, any orifice and check valve.
3. Assure minimum pressure valve (if so equipped) has proper setting.
4. Run unit at rated operating pressure for 30 to 40 minutes to permit element to clear itself.

---

## **EXTERIOR FINISH CARE**

This unit was painted and heat cured at the factory with a high quality, thermoset polyester powder coating. The following care will ensure the longest possible life from this finish.

1. **If necessary to remove dust, pollen, etc. from housing, wash with water and soap or dish washing liquid detergent. Do not scrub with a rough cloth, pad, etc.**
2. **If grease removal is needed, a fast evaporating alcohol or chlorinated solvent can be used. Note: This may cause some dulling of the paint finish.**
3. **If the paint has faded or chalked, the use of a commercial grade, non-abrasive car wax may partially restore the color and gloss.**
6. **Blow and tack the area to be painted.**
7. **Apply a smooth coat of Duponts 1854S Tuffcoat Primer to all bare metal areas and allow to dry.**
8. **Apply 2 medium - wet coats of Duponts 222S Adhesion Promoter over the entire area to be painted, with a 5 minute flash in between coats.**
9. **To apply the texture coat, use Duponts 1854S Tuffcoat Primer. The proper technique to do this is to spray the Tuffcoat Primer using a pressure pot and use about 2-5 pounds of air pressure. This will allow the primer to splatter causing the textured look. Note: you must be careful not to put too much primer on at one time, this will effect the amount of texture that you are trying to achieve. Allow the texture coat to flash for 20 minutes or until dry to touch.**

### **Field Repair of Texture Paint**

1. **The sheet metal should be washed and clean of foreign material and then thoroughly dried.**
  2. **Clean and remove all grease and wax from the area to be painted using Duponts 3900S Cleaner prior to sanding.**
  3. **Use 320 grit sanding paper to repair any scratches or defects necessary.**
  4. **Scuff sand the entire area to be painted with a red scotch brite pad.**
  5. **Wipe the area clean using Duponts 3900S.**
  10. **Apply any of Duponts Topcoat Finishes such as Imron™ or Centari™ according to the label instructions.**
- Note: To re-topcoat the textured surfaces when sheet metal repairs are not necessary, follow steps 1, 2, 4, 5, 6, 8 and 10.**

## **CAUTION**

Any unauthorized modification or failure to maintain this equipment may make it unsafe and out of factory warranty.

If performing more than visual inspections, disconnect battery cables and open manual blowdown valve.

Use extreme care to avoid contacting hot surfaces (engine exhaust manifold and piping, air receiver and air discharge piping, etc.).

Never operate this machine with any guards removed.

Inch and metric hardware was used in the design and assembly of this unit. Consult the parts manual for clarification of usage.

**Notice:** Disregard any maintenance pertaining to components not provided on your machine.

# MAINTENANCE SCHEDULE

These time periods should be reduced if operating in extreme conditions (very hot, cold, dusty or wet).

|   | Daily    | Weekly | Monthly | 3 MOS .   | 6 MOS.     | 12 MOS.    |
|---|----------|--------|---------|-----------|------------|------------|
| <b>SMALL UNITS (P100-P600)</b>                |          |        |         | 250 hours | 500 hours  | 1000 hours |
| <b>LARGE UNITS (HP600-P1600)</b>              |          |        |         | 500 hours | 1000 hours | 2000 hours |
| **Hydraulic Oil Level                         |          | C      |         |           | R          |            |
| Compressor Oil Level                          | C        |        |         |           |            |            |
| Engine Oil Level                              | C        |        |         |           |            |            |
| **Radiator Coolant Level                      | C        |        |         |           |            |            |
| Gauges/Lamps                                  | C        |        |         |           |            |            |
| Air Cleaner Service Indicators                | C        |        |         |           |            |            |
| Fuel Tank (fill at end of day)                | C        |        |         |           | DRAIN      |            |
| **Fuel/Water Separator                        | DRAIN C  |        |         |           |            |            |
| Air Cleaner Precleaner Dumps                  |          | C      |         |           |            |            |
| Fan/Alternator Belts                          |          | C      |         |           |            |            |
| Battery Connections/Electrolyte               |          | C      |         |           |            |            |
| **Tire Pressure and Surface                   |          | C      |         |           |            |            |
| **Wheel Lug Nuts                              |          |        | C       |           |            |            |
| Hoses (oil, air, intake, etc.)                |          |        | C       |           |            |            |
| Automatic Shutdown System                     | Test     |        | C       |           |            |            |
| Air Cleaner System                            | Visual   |        | C       |           |            |            |
| Compressor Oil Cooler                         | Exterior |        | C       | CLEAN     |            |            |
| **Engine Radiator                             | Exterior |        | C       | CLEAN     |            |            |
| Fasteners, Guards                             |          |        |         | C         |            |            |
| Air Cleaner Elements                          |          |        |         | WI        |            |            |
| ** Fuel/Water Separator Element               |          |        |         |           | R          |            |
| *Compressor Oil Filter Element                |          |        |         | B         | A          |            |
| *Compressor Oil                               |          |        |         |           | R          |            |
| **Wheels (bearings, seals, etc)               |          |        |         |           | C          | C          |
| Engine Coolant                                | Test     |        |         |           | C          | R          |
| Shutdown Switch Settings                      | Test     |        |         |           |            | C          |
| Scavenge Orifice & related parts              |          |        |         |           |            | CLEAN      |
| Oil Separator Element                         |          |        |         |           |            | R          |
| **Lights (running, brake, & turn)             | CBT      |        |         |           |            |            |
| **Pintle Eye Bolts                            | CBT      |        |         |           |            |            |
| Engine (oil changes, oil & fuel filters, etc) |          |        |         | R         |            |            |

\*\*Disregard if not appropriate for this particular machine.

\*NXP Units - consult manual

**R**=replace, **C**=check (adjust if necessary), **WI**=OR when indicated, **CBT** = check before towing.

**A** = Small Units

**B** = Large Units

Refer to specific sections of the operator's manual for more information.

---

# SECTION 7 - LUBRICATION

## GENERAL INFORMATION

Lubrication is an essential part of preventive maintenance, affecting to a great extent the useful life of the unit. Different lubricants are needed and some components in the unit require more frequent lubrication than others. Therefore, it is important that the instructions regarding types of lubricants and the frequency of their application be explicitly followed. Periodic lubrication of the moving parts reduces to a minimum the possibility of mechanical failures.

The Preventive Maintenance Schedule shows those items requiring regular service and the interval in which they should be performed. A regular service program should be developed to include all items and fluids. These intervals are based on average operating conditions. In the event of extremely severe (hot, cold, dusty or wet) operating conditions, more frequent lubrication than specified may be necessary. Details concerning lubrication of the running gear are in Maintenance Section.

All filters and filter elements for air and compressor lubricant must be obtained through Ingersoll-Rand to assure the proper size and filtration for the compressor.

## COMPRESSOR OIL CHANGE

These units are normally furnished with an initial supply of oil sufficient to allow operation of the unit for approximately 6 months or 1000 hours, whichever comes first. If a unit has been completely drained of all oil, it must be refilled with new oil before it is placed in operation. Refer to specifications in Lubrication Table.

### **NOTICE**

Some oil types are incompatible when mixed and result in the formation of varnishes, shellacs, or lacquers which may be insoluble. Such deposits can cause serious troubles including clogging of the filters. Where possible, do NOT mix oils of different types and avoid mixing different brands. A type or brand change is best made at the time of a complete oil drain and refill.

If the unit has been operated for the time/ hours mentioned above, it should be completely drained of oil. If the unit has been operated under adverse conditions, or after long periods in storage, an earlier change period may be necessary as oil deteriorates with time as well as by operating conditions.

### **WARNING**

**High pressure air can cause severe injury or death from hot oil and flying parts. Always relieve pressure before removing caps, plugs, covers or other parts from pressurized air system. Ensure the following conditions are met:**

- Discharge air pressure gauge reads zero (0).
- No air discharging from an "open" manual blowdown valve.

An oil change is good insurance against the accumulation of dirt, sludge, or oxidized oil products.

Completely drain the receiver- separator, piping, and oil cooler. If the oil is drained immediately after the unit has been run for some time, most of the sediment will be in suspension and, therefore, will drain more readily. However, the fluid will be hot and care must be taken to avoid contact with the skin or eyes.

After the unit has been completely drained of all old oil, close the drain valve. Add oil in the specified quantity at the filler plug. Tighten the filler plug and run the machine to circulate the oil. Check the oil level WHEN RUNNING AT FULL LOAD. If not near the middle of the sight tube, stop the unit and make corrections. DO NOT OVERFILL.

### **NOTICE**

Ingersoll-Rand provides compressor oil specifically formulated for Portable Compressors and requires the use of these fluids in order to obtain extended limited airtend warranty.

## SECTION 7 - COMPRESSOR LUBRICATION

### Portable Compressor Fluid Chart

Refer to these charts for correct compressor fluid required. Note that the selection of fluid is dependent on the design operating pressure of the machine and the ambient temperature expected to be encountered before the next oil change.

| Design Operating Pressure | Ambient Temperature               | Specification                        |
|---------------------------|-----------------------------------|--------------------------------------|
| 100 psi to 300 psi        | -10°F to 125°F<br>(-23°C to 52°C) | IR Pro-Tec™<br>Mil-PRF 2104G SAE 10W |
| 100 psi to 300 psi        | -40°F to 125°F<br>(-40°C to 52°C) | IR Performance 500<br>Mil-L-46167    |
| 350 psi                   | -10°F to 125°F<br>(-23°C to 52°C) | IR XHP 505                           |
|                           | 65°F to 125°F<br>(18°C to 52°C)   | IR XHP1001                           |
|                           | -40°F to 65°F<br>(-40°C to 18°C)  | IR Performance 500<br>Mil-L-46167    |
| 500 psi                   | 50°F to 125°F<br>(10°C to 52°C)   | IR XHP1001                           |
|                           | 10°F to 65°F<br>(-12°C to 18°C)   | IR XHP 505                           |
|                           | below 10°F<br>(-12°C)             | Consult Factory                      |

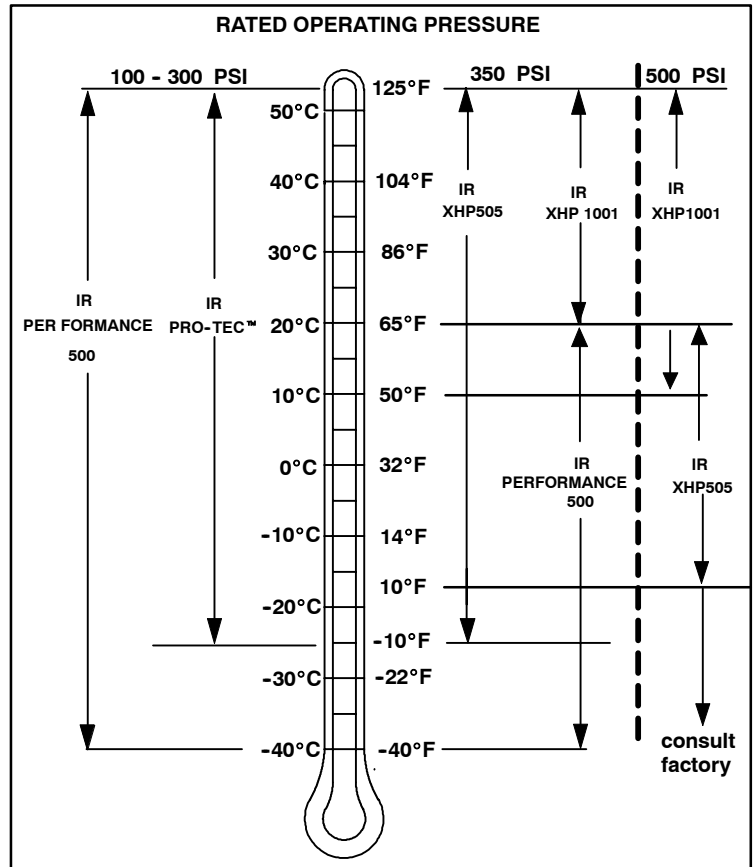

Recommended Ingersoll-Rand Fluids - Use of these fluids with original I-R filters can extend airend warranty. Refer to operator's manual warranty section for details or contact your I-R representative.

| Recommended Fluid  | 1 Gal. (3.8 Litre) | 5 Gal. (19.0 Litre) | 55 Gal. (208.2 Litre) |
|--------------------|--------------------|---------------------|-----------------------|
| IR Pro-Tec™        | 36899698           | 36899706            | 36899714              |
| IR XHP 505         |                    | 35365188            | 35365170              |
| IR Performance 500 | 35382928           | 35382936            | 35382944              |
| IR XHP1001         |                    | 35612738            | 35300516              |



---

# **SECTION 8 - Trouble Shooting**

## **INTRODUCTION**

Trouble shooting for a portable air compressor is an organized study of a particular problem or series of problems and a planned method of procedure for investigation and correction. The trouble shooting chart that follows includes some of the problems that an operator may encounter during the operation of a portable compressor.

The chart does not attempt to list all of the troubles that may occur, nor does it attempt to give all of the answers for correction of the problems. The chart does give those problems that are most apt to occur. To use the trouble shooting chart:

- A. Find the "complaint" depicted as a bold heading.
- B. Follow down that column to find the potential cause or causes. The causes are listed in order (1,2,3 etc.) to suggest an order to follow in trouble shooting.

## **ACTION PLAN**

### **A. Think Before Acting**

Study the problem thoroughly and ask yourself these questions:

- (1) What were the warning signals that preceded the trouble?
- (2) Has a similar trouble occurred before?
- (3) What previous maintenance work has been done?
- (4) If the compressor will still operate, is it safe to continue operating it to make further checks?

### **B. Do The Simplest Things First**

Most troubles are simple and easily corrected. For example, most complaints are "low capacity" which may be caused by too low an engine speed or "compressor over- heats" which may be caused by low oil level.

Always check the easiest and most obvious things first; following this simple rule will save time and trouble.

**Note:** For trouble shooting electrical problems, refer to the Wiring Diagram Schematic found in Parts List Section.

### **C. Double Check Before Disassembly**

The source of most compressor troubles can be traced not to one component alone, but to the relationship of one component with another. Too often, a compressor can be partially disassembled in search of the cause of a certain trouble and all evidence is destroyed during disassembly. Check again to be sure an easy solution to the problem has not been overlooked.

### **D. Find And Correct Basic Cause**

After a mechanical failure has been corrected, be sure to locate and correct the cause of the trouble so the same failure will not be repeated. A complaint of "premature breakdown" may be corrected by repairing any improper wiring connections, but something caused the defective wiring. The cause may be excessive vibration.

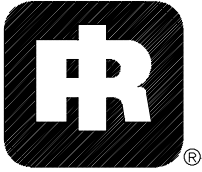

# TROUBLE SHOOTING CHART

**Bold Headings depict the COMPLAINT - Subheadings suggest the CAUSE**

Note: Subheadings suggest sequence to follow troubleshooting.

## **1. Unit Shutdown:**

|                                      | <b><u>Corrective Action</u></b>                            |
|--------------------------------------|--|
| Out of Fuel                          | Add CLEAN diesel Fuel                                      |
| Compressor Oil Temp. Too High        | See Complaint 10   |
| Engine Water Temp. Too High          | Check coolant level. If necessary, Add.                    |
| Engine Oil Pressure Too Low          | See Complaint 3 and Complaint 4.                           |
| Broken Engine Fan Belt               | Replace fan belt.  |
| Loose Wire Connection                | Wiggle wires at switches & connector blocks. Make repairs. |
| Low Fuel Level Shutdown Switch       | Replace switch.  |
| Defective Discharge Air Temp. Switch | Replace switch.  |
| Defective Engine Oil Pressure Switch | Replace switch.  |
| Defective Shutdown Solenoid          | Replace solenoid.  |
| Malfunctioning Relay                 | Replace relay.   |
| * < 16 Volts at Shutdown Solenoid    | Check battery and alternator. Make repairs.                |
| Blown Fuse                           | Replace fuse.  |
| Engine Malfunctioning                | See Trouble Shooting in Engine Manual.                     |
| Airend Malfunctioning                | See Complaint 10.  |

## **2. Won't Start/Run:**

|                                      |  |
|--------------------------------------|--|
| Low Battery Voltage                  | Check electrolyte level. Check connections.    |
| * <16 Volts at Shutdown Solenoid     | Charge battery and alternator. Make repairs.   |
| Blown Fuse                           | Replace fuse.                                  |
| Malfunctioning Start Switch          | Replace switch.                                |
| Defective Safety Bypass Switch       | Replace switch.                                |
| Clogged Fuel Filters                 | Service filters. See Engine Operator's Manual. |
| Out of Fuel                          | Add CLEAN fuel.                                |
| Compressor Oil Temp. Too High        | See Complaint 10.                              |
| Engine Water Temp. Too High          | Check fluid level. If necessary, Add.          |
| Engine Oil Pressure Too Low          | See Complaint 3 and Complaint 4.               |
| Loose Wire Connection                | Repair or replace connection.                  |
| Defective Discharge Air Temp. Switch | Replace switch.                                |
| Defective Engine Oil Pressure Switch | Replace switch.                                |
| Defective Shutdown Solenoid          | Replace solenoid.                              |
| Malfunctioning Relay                 | Replace relay.                                 |
| Engine Malfunctioning                | See Trouble Shooting in Engine Manual.         |
| Airend Malfunctioning                | See Complaint 10.                              |

## **3. Engine Temperature Lamps Stays On:**

|                               |                                   |
|-------------------------------|-----------------------------------|
| Broken Engine Fan Belt        | Replace fan belt set.             |
| Malfunctioning Circuit Board  | Replace circuit board.            |
| * Ambient Temp. >125°F (52°C) | Above spec limit.                 |
| Dirty Operating Conditions    | Move unit to cleaner environment. |
| Dirty Cooler                  | Clean exterior of cooler.         |
| * Out of Level >15 degrees    | Relocate or reposition unit.      |
| Operating Pressure Too High   | Reduce pressure to spec.          |
| Recirculation of Cooling Air  | Close side doors.                 |
| Loose Wire Connection         | Repair or replace.                |
| Malfunctioning circuit board. | Replace circuit board.            |

\* : > = greater than, < = less than

---

**4. Engine Oil Pressure Lamp Stays On:**

Low Oil Level  
Out of Level >15 degrees  
Wrong Lube Oil  
Clogged Oil Filter Element(s)  
Engine Malfunctioning  
Loose Wire Connection.  
Malfunctioning circuit board

**Corrective Action**

Add oil.  
Relocate or reposition.  
See Engine Oil Spec. Change oil.  
Replace element(s).  
See Trouble Shooting in Engine Manual.  
Repair or replace.  
Replace circuit.

**5. Engine Temperature Lamps Stays Off:**

Bulb Burned Out  
Malfunctioning circuit board

Replace circuit board.  
Replace circuit board.

**6. Engine Oil Pressure Lamp Stays Off:**

Bulb Burned Out  
Malfunctioning circuit board

Replace circuit board.  
Replace circuit board.

**7. Alternator Lamp Stays On:**

Loose or Broken Belts  
Loose Wire Connection  
Low Battery Voltage  
  
Malfunctioning Alternator  
Malfunctioning circuit board

Tighten or replace belt set.  
Repair or replace connection.  
Check electrolyte level. Add if necessary.  
Check connectors. Clean & tighten.  
Recharge battery.  
Repair or replace alternator.  
Replace circuit board.

**8. Alternator Lamp Stays Off:**

Bulb Burned Out  
Loose Wire Connection  
Malfunctioning circuit board

Replace circuit board.  
Repair or replace connector.  
Replace circuit board.

**9. Unit Fails To Shutdown:**

Defective Low Fuel Shutdown Switch  
Defective Discharge Air Temperature Switch  
Defective Engine Oil Pressure Switch  
Defective Shutdown Solenoid  
Malfunctioning Relay  
Defective Safety Bypass Switch

Pull wire off shutdown solenoid. Replace switch.  
Pull wire off. Replace switch.  
Pull wire off. Replace switch.  
Carefully block air inlet to stop engine.  
Replace solenoid.  
Pull wire off shutdown solenoid. Replace relay.  
Pull wire off shutdown solenoid. Replace defective item.

---

## **10. Excessive Compressor Oil Temperature:**

Ambient Temp. > 125°F (52°C)  
Out of Level > 15 degrees  
Low Oil Level  
Wrong Lube Oil  
Dirty Cooler  
Dirty Operating Conditions  
Clogged Oil Filter Elements  
Loose or Broken Belts  
Operating Pressure Too High  
Recirculation Of Cooling Air  
Malfunctioning Thermostat  
Malfunctioning Fan  
Defective Oil Cooler Relief Valve  
Defective Minimum Pressure Valve  
Blocked or Restricted Oil Lines  
Airend Malfunctioning

## **Corrective Action**

Above spec limit.  
Relocate or reposition unit.  
Add oil. Look for any leaks.  
Check spec in this manual.  
Clean exterior surfaces.  
Move unit to cleaner environment.  
Replace elements. Change oil.  
Tighten or replace belt set.  
Reduce pressure to spec.  
Close side doors. Replace belly pan.  
Replace thermostat in bypass valve.  
Check fan belt tension. Tighten or replace belt set.  
Replace valve.  
Repair or replace valve.  
Clean by flushing or replace.  
See Complaint 11, 12, 13, 15, 16 or 18.

## **11. Engine RPM Down:**

Clogged Fuel Filter  
  
Operating Pressure Too High  
Incorrect Pressure Regulator Adjustment  
Malfunctioning Pressure Regulator  
Incorrect Linkage Adjustment  
Dirty Air Filter  
Malfunctioning Air Cylinder  
Wrong Air Filter Element  
Defective Separator Element  
Engine Malfunctioning  
Airend Malfunctioning

Clean primary filter. Replace final filter. Drain tanks.  
Add CLEAN fuel.  
Reduce pressure to spec limit.  
See Section 6 in this manual.  
Replace regulator.  
See Section 6 in this manual.  
Clean or replace elements.  
Replace air cylinder and adjust per Section 6.  
Install correct element.  
Install new element per page 21.  
See Trouble Shooting in Engine Manual.  
Refer to Airend Rebuild Manual.

## **12. Excessive Vibration:**

Rubber Mounts, Loose or Damaged  
Defective Fan  
Drive Coupling Defective  
Engine Malfunctioning  
Airend Malfunctioning  
Anti-rumble valve not working.  
Engine idle speed too low.

Tighten or replace.  
Replace fan.  
Replace coupling.  
See Trouble Shooting in Engine Manual.  
See Complaint 15 and 17.  
Repair or Replace.  
Raise "No Load" speed per Section 6.

## **13. Low CFM:**

Dirty Air Filter  
Incorrect Linkage Adjustment  
Incorrect Pressure Regulator Adjustment  
Malfunctioning Pressure Regulator  
Malfunctioning Inlet Unloader/Butterfly Valve  
Malfunctioning Air Cylinder  
Defective Minimum Pressure Valve  
Defective Separator Element  
Wrong Air Filter Element

Clean or replace elements.  
See Section 6 in this manual.  
See Section 6 in this manual.  
Replace regulator.  
Inspect valve. Make adjustment per Section 6.  
Replace air cylinder.  
Repair or replace valve.  
Install new element per Page 21.  
Install correct element.

---

#### **14. Short Air Cleaner Life:**

Dirty Operating Conditions  
Inadequate Element Cleaning  
Incorrect Stopping Procedure  
Wrong Air Filter Element  
Oil Pump Drive Coupling

#### **Corrective Action**

Move unit to cleaner environment.  
Install new element.  
Read procedure in this manual.  
Install proper element.  
Inspect coupling. If necessary, replace coupling.

#### **15. Excessive Oil In Air:**

High Oil Level  
Out of Level > 15 degrees  
Clogged Scavenge Orifice  
Scavenge Tube Blocked  
Defective Scavenge Check Valve  
Sep. Tank Blow Down Too Quickly  
Defective Minimum Pressure Valve

Read procedure in this manual.  
Relocate or reposition unit.  
Remove scavenge orifice. Clean and Replace.  
Remove scavenge tube. Clean and Replace.  
Remove check valve. Replace with new valve.  
Allow unit to blow down automatically.  
Remove valve. Repair valve and replace.

#### **16. Oil Seal Leak:**

Contaminated Lube Oil  
Blocked or Restricted Oil Line(s)  
Malfunctioning Seal  
Scored Shaft

Drain and flush system. Add new CLEAN oil.  
Remove, clean and replace line(s).  
Refer to Airend Rebuild Manual.  
See instructions in new seal kit.

#### **17. Will Not Unload:**

Leak in Regulator Piping  
Incorrect Pressure Regulator Adjustment  
Malfunctioning Pressure Regulator  
Malfunctioning Inlet Butterfly Valve  
Ice in Regulation Lines/Orifice

Find and repair leak(s).  
Refer to Section 6 in this manual.  
Replace regulator.  
Inspect valve fit. Readjust per Section 6.  
Apply heat to line(s) and or orifice.

#### **18. Oil In Air Cleaner:**

Incorrect Stopping Procedure  
Oil Pump Drive Coupling  
Discharge Check Valve Faulty

Read Procedure in this manual.  
Inspect coupling. Replace if necessary.  
Replace.

#### **19. Safety Valve Relieves:**

Operating Pressure Too High  
Leak In Regulator Piping  
Incorrect Pressure Regulator Adjustment  
Malfunctioning Pressure Regulator  
Malfunctioning Inlet Unloader/Butterfly Valve  
Defective Safety Valve  
Defective Separator Element  
Ice in Regulation Lines/Orifice

Reduce pressure to spec limit.  
Repair leak(s).  
Refer to Section 6 in this manual.  
Replace regulator.  
Inspect valve fit. Readjust per Section 6.  
Replace safety valve.  
Remove element. Install new.  
Apply heat to lines and/or orifice.

---

# SECTION 9 - PARTS ORDERING

## GENERAL

This publication, which contains an illustrated parts breakdown, has been prepared as an aid in locating those parts which may be required in the maintenance of the unit. All of the compressor parts, listed in the parts breakdown, are manufactured with the same precision as the original equipment. For the greatest protection always insist on genuine Ingersoll-Rand Company parts for your compressor.

## **NOTICE**

Ingersoll-Rand Company can bear no responsibility for injury or damages resulting directly from the use of non-approved repair parts.

Ingersoll-Rand Company service facilities and parts are available worldwide. There are Ingersoll-Rand Company Construction Equipment Group Sales Offices and authorized distributors located in the principal cities of the United States. In Canada our customers are serviced by the Canadian Ingersoll-Rand Company, Limited. There are also Ingersoll-Rand International autonomous companies and authorized distributors located in the principal cities throughout the free world.

Special order parts may not be included in this manual. Contact the Mocksville Parts Department with the unit serial number for assistance with these special parts.

## DESCRIPTION

The illustrated parts breakdown illustrates and lists the various assemblies, subassemblies and detailed parts which make up this particular machine. This covers the standard models and the more popular options that are available.

A series of illustrations show each part distinctly and in

location relative to the other parts in the assembly. The part number, the description of the part and the quantity of parts required are shown on each illustration or on adjacent page. The quantities specified are the number of parts used per one assembly and are not necessarily the total number of parts used in the machine. Where no quantity is specified the quantity is assumed to be one.

Each description of a part is based upon the "noun first" method, i.e., the identifying noun or item name is always the first part of the description. The noun name is generally followed by a single descriptive modifier. The descriptive modifier may be followed by words or abbreviations such as upper, lower, inner, outer, front, rear, RH, LH, etc. when they are essential.

In referring to the rear, the front or to either side of the unit, always consider the **drawbar end** of the unit as the **front**. Standing at the rear of the unit facing the drawbar (front) will determine the right and left sides.

## FASTENERS

Both SAE/inch and ISO/metric hardware have been used in the design and assembly of these units. In the disassembly and reassembly of parts, extreme care must be taken to avoid damaging threads by the use of wrong fasteners. In order to clarify the proper usage and for exact replacement parts, all standard fasteners have been identified by part number, size and description. This will enable a customer to obtain fasteners locally rather than ordering from the factory. These parts are identified in tables that will be found at the rear of the parts illustrations. Any fastener that has not been identified by both part number and size is a specially engineered part that must be ordered by part number to obtain the exact replacement part.

## MARKINGS AND DECALS

### NOTICE

**Do not paint over safety warnings or instructional decals. If safety warning decals become illegible, immediately order replacements from the factory.**

Part numbers for original individual decals and their mounting locations are shown within Parts List Section. These are available as long as a particular model is in production.

Afterwards, service sets of exterior decals and current production safety warning decals are available. Contact the Product Support Group at Mocksville for your particular needs and availability.

### HOW TO USE PARTS LIST

- a. Turn to Parts List.
- b. Locate the area or system of the compressor in which the desired part is used and find illustration page number.
- c. Locate the desired part on the illustration by visual identification and make note of part number and description.

### HOW TO ORDER

The satisfactory ordering of parts by a purchaser is greatly dependent upon the proper use of all available information. By supplying your nearest sales office, autonomous company or authorized distributor, with complete information, you will enable them to fill your order correctly and to avoid any unnecessary delays.

In order that all avoidable errors may be eliminated, the following instructions are offered as a guide to the purchaser when ordering replacement parts:

- a. Always specify the model number of the unit as shown on the general data decal attached to the unit.
- b. Always specify the serial number of the unit. **THIS IS IMPORTANT.** The serial number of the unit will be found stamped on a plate attached to the unit. (The serial number on the unit is also permanently stamped in the metal of the frame side rail.)

- c. Always specify the number of the parts list publication.
- d. Always specify the quantity of parts required.
- e. Always specify the part number, as well as the description of the part, or parts, exactly as it is given on the parts list illustration.

In the event parts are being returned to your nearest sales office, autonomous company or authorized distributor, for inspection or repair, it is important to include the serial number of the unit from which the parts were removed.

### TERMS AND CONDITIONS ON PARTS ORDERS

**Acceptance:** Acceptance of an offer is expressly limited to the exact terms contained herein. If purchaser's order form is used for acceptance of an offer, it is expressly understood and agreed that the terms and conditions of such order form shall not apply unless expressly agreed to by Ingersoll-Rand Company ("Company") in writing. No additional or contrary terms will be binding upon the Company unless expressly agreed to in writing.

**Taxes:** Any tax or other governmental charge now or hereafter levied upon the production, sale, use or shipment of material and equipment ordered or sold is not included in the Company's price and will be charged to and paid for by the Purchaser.

Shipping dates shall be extended for delays due to acts of God, acts of Purchaser, acts of Government, fires, floods, strikes, riot, war, embargo, transportation shortages, delay or default on the part of the Company's vendors, or any other cause beyond the Company's reasonable control.

Should Purchaser request special shipping instruction, such as exclusive use of shipping facilities, including air freight when common carrier has been quoted and before change order to purchase order can be received by the Company, the additional charges will be honored by the Purchaser.

---

**Warranty:** The Company warrants that parts manufactured by it will be as specified and will be free from defects in materials and workmanship. The Company's liability under this warranty shall be limited to the repair or replacement of any part which was defective at the time of shipment provided Purchaser notifies the Company of any such defect promptly upon discovery, but in no event later than three (3) months from the date of shipment of such part by the Company. The only exception to the previous statement is the extended warranty as it applies to the special airend exchange program.

Repairs and replacements shall be made by the Company F.O.B. point of shipment. The Company shall not be responsible for costs of transportation, removal or installation.

Warranties applicable to material and equipment supplied by the Company but wholly manufactured by others shall be limited to the warranties extended to the Company by the manufacturer which are able to be conveyed to the Purchaser.

**Delivery:** Shipping dates are approximate. The Company will use best efforts to ship by the dates specified; however, the Company shall not be liable for any delay or failure in the estimated delivery or shipment of material and equipment or for any damages suffered by reason thereof.

The company makes no other warranty or representation of any kind whatsoever, expressed or implied, except that of title, and all implied warranties, including any warranty of merchantability and fitness for a particular purpose, are hereby disclaimed.

**Limitation of Liability:**

The remedies of the Purchaser set forth herein are exclusive, and the total liability of the Company with respect to this order whether based on contract, warranty, negligence, indemnity, strict liability or otherwise, shall not exceed the purchase price of the part upon which such liability is based.

The Company shall in no event be liable to the Purchaser, any successors in interest or any beneficiary of this order for any consequential, incidental, indirect, special or punitive damages arising out of this order or any breach thereof, or any defect in, or failure of, or malfunction of the parts hereunder, whether based upon loss of use, lost profits or revenue, interest, lost goodwill, work stoppage, impairment of other goods, loss by reason of shutdown or non-operation, increased expenses of operation or claims of customers of Purchaser for service interruption whether or not such loss or damage is based on contract, warranty, negligence, indemnity, strict liability or otherwise.



---

## **AIREND EXCHANGE PROGRAM**

Your Ingersoll-Rand Company Construction Equipment Group Sales Offices and authorized distributors as well as Ingersoll-Rand International autonomous companies and authorized distributors now have an airend exchange program to benefit portable compressor users.

**On the airend exchange program the exchange price is determined by the age and condition of the airend and may be classified by one of the following categories.**

**Category “A”:** The airend must not be over two years old and must have reusable rotor housing(s) and rotor(s).

**Category “B”:** The airend must be between two and five years old and returned with two or more reusable major castings.

**Category “C”:** The airend must be over five years old.

Your nearest sales office, autonomous company or authorized distributor must first contact the Parts Service Department at the factory at which your portable air compressor was manufactured for an airend exchange number. The airend must be tagged with this preassigned number and returned to the factory pre-paid. The airend must be intact, with no excluded parts, otherwise the exchange agreement may be cancelled. The warranty on an exchange or factory rebuilt airend is 365 days.

## **NOTICE**

**Airends being returned to the factory in connection with a WARRANTY CLAIM must be processed through the Customer Service Department. If returned without a Warranty MRR (Material Return Request) Number, no warranty claim will be considered.**

## SECTION 10 - PARTS LIST INDEX

---

General Arrangement Drawing  
Frame & Running Gear, Sht 1  
Frame & Running Gear, Sht 2  
Jack Assembly, Sht 1  
Jack Assembly, Sht 2  
Brake Actuator Assembly, Sht 1  
Brake Actuator Assembly, Sht 2  
Running Gear Complete, Sht 1  
Running Gear Complete, Sht 2  
Engine Complete, Sht 1  
Engine Complete, Sht 2  
Exhaust Complete, Sht 1  
Exhaust Complete, Sht 2  
Airend Complete, Sht 1  
Airend Complete, Sht 2  
Airend Assembly, Sht 1  
Airend Assembly, Sht 2  
Airend Assembly, Sht 3  
Airend Assembly, Sht 4  
Airend Assembly, Sht 5  
Airend Assembly, Sht 6  
Unloader Assembly, Sht 1  
Unloader Assembly, Sht 2  
Rad & Oil Clr Cmpl, Sht 1  
Rad & Oil Clr Cmpl, Sht 2  
Radiator Piping, Sht 1  
Radiator Piping, Sht 2  
Parking Brakes, Sht 1  
Parking Brakes, Sht 2  
Brake Line Piping, Sht 1  
Brake Line Piping, Sht 2  
Separator Tank Complete, Sht 1  
Separator Tank Complete, Sht 2  
Minimum Pressure Valve, Sht 1  
Minimum Pressure Valve, Sht 2

## PARTS LIST INDEX

---

Oil Temp Bypass Vlv & Filter , Sht 1  
Oil Temp Bypass Vlv & Filter , Sht 2  
Fuel Tank Complete, Sht 1  
Fuel Tank Complete, Sht 2  
Air Piping, Sht 1  
Air Piping, Sht 2  
Oil Piping, Sht 1  
Oil Piping, Sht 2  
Oil Piping, Sht 3  
Oil Piping, Sht 4  
Air End Piping, Sht1  
Air End Piping, Sht2  
Air End Piping, Sht3  
Air End Piping, Sht4  
Air Intake Complete, Sht 1  
Air Intake Complete, Sht 2  
Battery & Mounting , Sht 1  
Battery & Mounting , Sht 2  
Instr/Control Panel, Sht 1  
Instr/Control Panel, Sht 2  
Instr/Control Panel, Sht 3  
Instr/Control Panel, Sht 4  
Enclosure Complete, Sht 1  
Enclosure Complete, Sht 2  
Enclosure Complete, Sht 3  
Enclosure Complete, Sht 4  
Enclosure Complete, Sht 5  
Enclosure Complete, Sht 6  
Acoustic Panels, Sht 1  
Acoustic Panels, Sht 2  
Starting Aid Complete, Sht 1  
Starting Aid Complete, Sht 2  
Decal Location, Sht 1  
Decal Location, Sht 2  
Decal Location, Sht 3  
Decal Location, Sht 4  
Wiring Diagram & Parts List , Sht 1  
Wiring Diagram & Parts List , Sht 2  
Wiring Diagram & Parts List , Sht 3  
Wiring Diagram & Parts List , Sht 4  
Internal Baffles & Foam , Sht 1  
Internal Baffles & Foam , Sht 2  
Running Lights, Sht 1  
Running Lights, Sht 2  
Running Lights, Sht 3  
Running Lights, Sht 4

SEPARATOR TANK ASSEMBLY

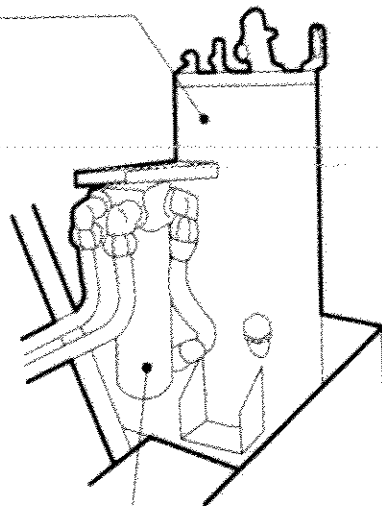

COMPRESSOR OIL FILTER ASSEMBLY

OIL COOLER ASSEMBLY

ENGINE AIR FILTER

RADIATOR ASSEMBLY

EXHAUST ASSEMBLY

JACK ASSEMBLY

FUEL TANK

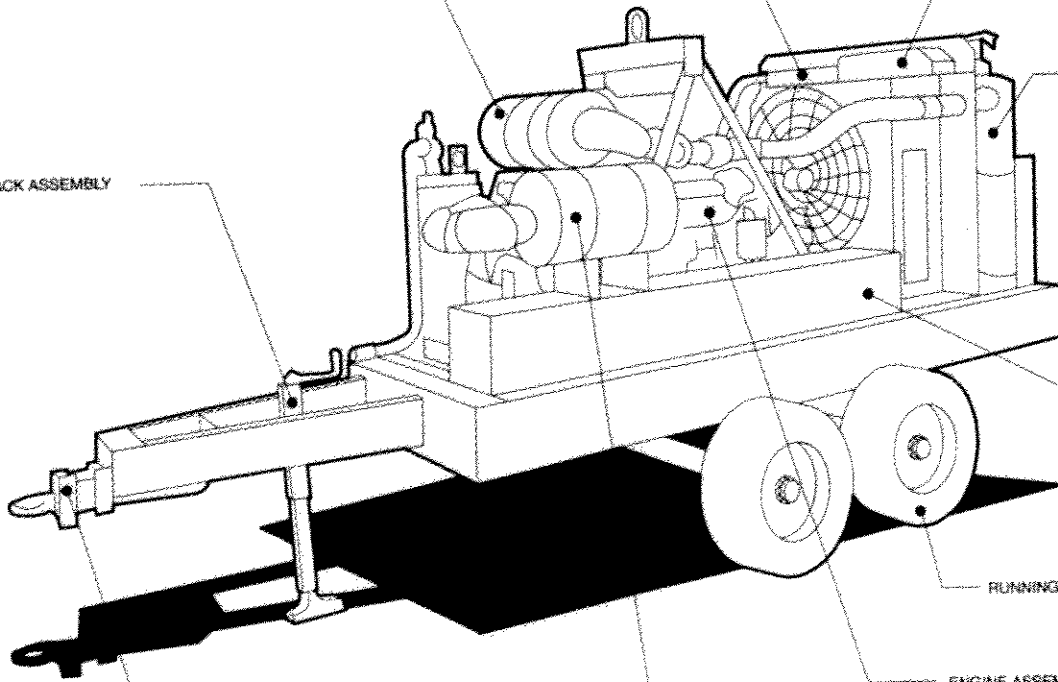

RUNNING GEAR ASSEMBLY

ENGINE ASSEMBLY

DRAWBAR AND BRAKE ACTUATOR

AIR END AIR FILTER

|                              |            |                     |  |
|------------------------------|------------|---------------------|--|
| INGERSOLL-RAND COMPANY       |            |                     |  |
| PORTABLE COMPRESSOR DIVISION |            |                     |  |
| DATE/DOWN BY:                |            | DESCRIPTION:        |  |
| 2-00                         | WAP        | GENERAL ARRANGEMENT |  |
| MODEL NO.                    | MANUAL NO. | DATE/REV.           |  |
| JD                           | 35389923-2 | 2-00/8              |  |
| DELUXE                       |            |                     |  |

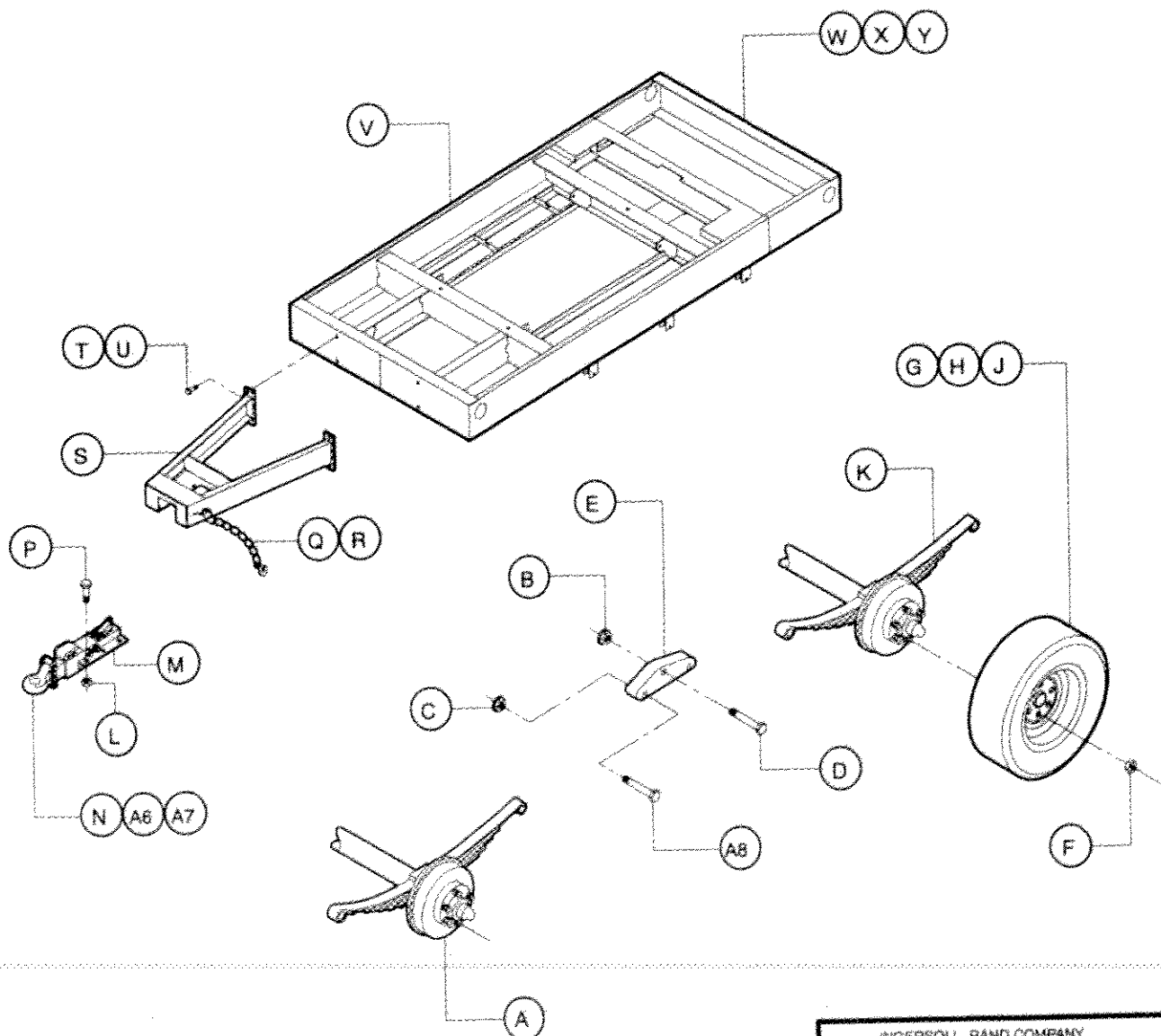
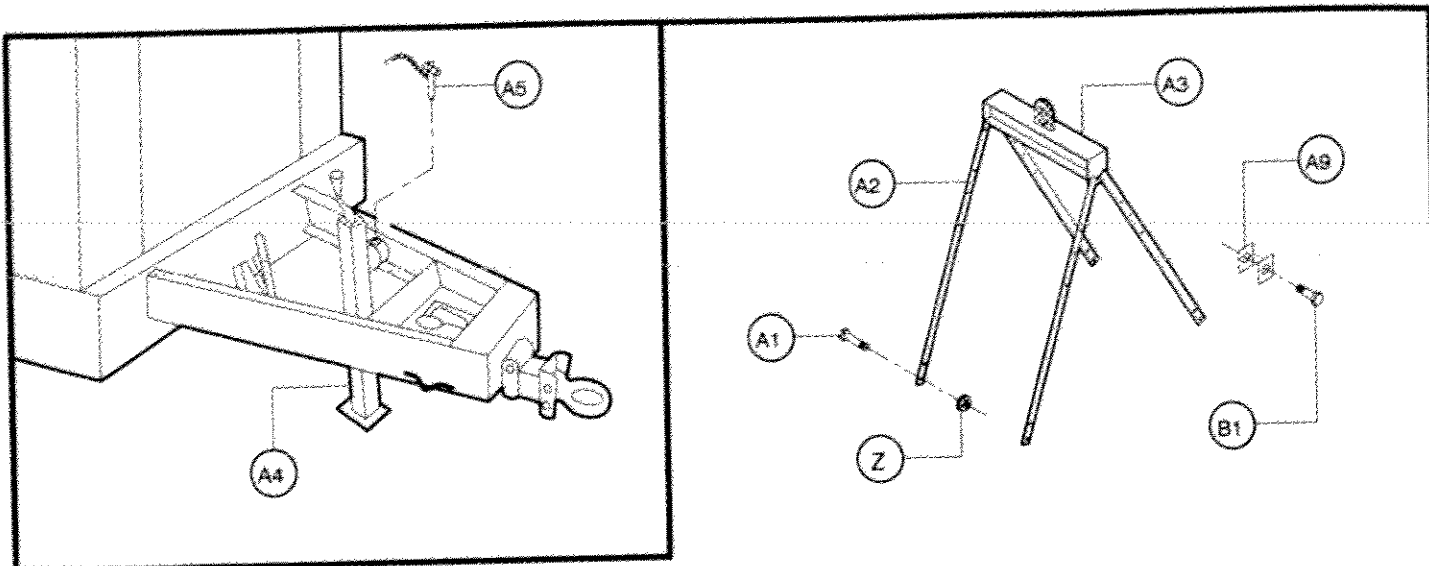

|                              |                        |           |
|------------------------------|------------------------|-----------|
| INGERSOLL-RAND COMPANY       |                        |           |
| PORTABLE COMPRESSOR DIVISION |                        |           |
| DATE/OWN BY:                 | DESCRIPTION            |           |
| 2-00 WAP                     | FRAME AND RUNNING GEAR |           |
| MODEL NO.                    | MANUAL NO.             | DATE/REV. |
| JD                           | 35389923-3             | 2-00 / C  |
| DEUCE                        |                        |           |

|     |          |                       |      |            |                     |          |
|-----|----------|-----------------------|------|------------|---------------------|----------|
| (A) | 36967598 | FRONT AXLE ASSEMBLY   | (U)  | 35356526   | NUT                 | (4 REQD) |
| (B) | 36784882 | NUT, SHACKLE          | (V)  | 36896801   | FRAME, MAIN         |          |
| (C) | 35315373 | NUT, SHACKLE          | (W)  | 35896818   | FRAME, EXTENSION    |          |
| (D) | 36784874 | BOLT, SHACKLE         | (X)  | 34M2AB462  | SCREW               | (4 REQD) |
| (E) | 36784866 | EQUALIZER             | (Y)  | 16M4JC26M3 | NUT                 | (4 REQD) |
| (F) | 35385251 | NUT (24 REQD)         | (Z)  | 35297340   | NUT                 | (8 REQD) |
| (G) | 36021806 | WHEEL & TIRE ASSEMBLY | (A1) | 34M2AB513  | SCREW               | (6 REQD) |
| (H) | 35385525 | WHEEL                 | (A2) | 36866333   | STRAP, LIFTING BAIL |          |
| (J) | 35278332 | TIRE                  | (A3) | 36866341   | BAIL, LIFTING       |          |
| (K) | 36867653 | REAR AXLE ASSEMBLY    | (A4) | 36752228   | JACK                |          |
| (L) | 35356526 | NUT (6 REQD)          | (A5) | 35609544   | PIN, QUICK RELEASE  |          |
| (M) | 36867299 | ACTUATOR, BRAKE       | (A6) | 35376094   | SCREW               |          |
| (N) | 35805187 | PINTLE EYE            | (A7) | 16M4JC26M3 | NUT                 | (4 REQD) |
| (P) | 35272558 | SCREW (6 REQD)        | (A8) | 35315385   | BOLT, SHACKLE       |          |
| (Q) | 36610377 | CHAIN & HOOK ASSEMBLY | (A9) | 36877546   | SPACER              |          |
| (R) | 35372432 | COUPLING              | (B1) | 35375385   | SCREW               |          |
| (S) | 36866283 | DRAWBAR               |      |            |                     |          |
| (T) | 35375377 | SCREW (4 REQD)        |      |            |                     |          |

### PARTS NOT ILLUSTRATED

|          |                                    |
|----------|------------------------------------|
| 36866317 | FRONT BELLY PAN                    |
| 36866325 | ENGINE BELLY PAN                   |
| 36867174 | ENGINE OIL DRAIN COVER             |
| 36867182 | RADIATOR & OIL COOLER ACCESS COVER |

| INGERSOLL-RAND COMPANY<br>PORTABLE COMPRESSOR DIVISION |                          |                        |
|--|--------------------------|------------------------|
| GATEWAY NO.  | DESCRIPTION              |                        |
| 2-00   | WAF                      | FRAME AND RUNNING GEAR |
| MODEL NO.<br>JD<br>DEUCE                               | MANUAL NO.<br>35389923-4 | DATE REV.<br>2-00 / C  |

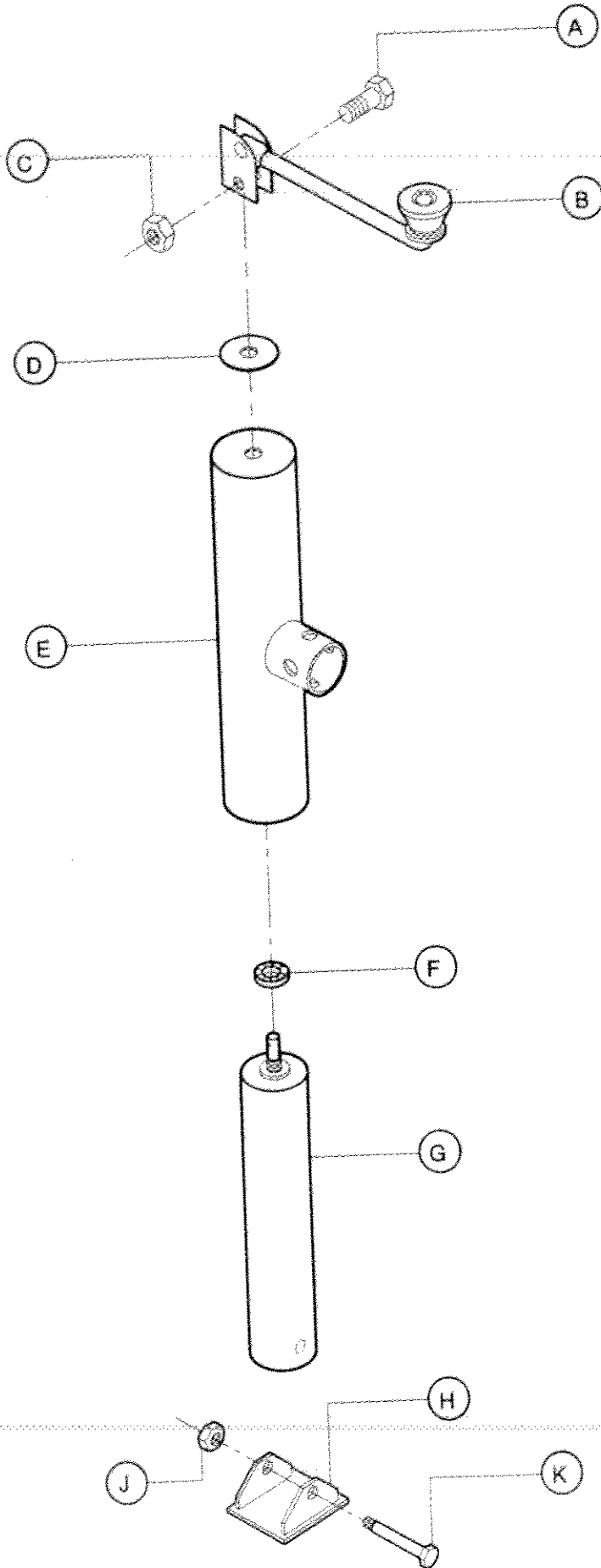

| INGERSOLL-RAND COMPANY<br>PORTABLE COMPRESSION DIVISION |               |           |
|---|---------------|-----------|
| DATE/DWN BY:  | DESCRIPTION   |           |
| 2-00 WAP  | JACK ASSEMBLY |           |
| MODEL NO.   | MANUAL NO.    | DATE/REV. |
| J0<br>DEUCE   | 35389923-5    | 2-00 / B  |

- (A) 35A2D62Z1 BOLT
- (B) 36870061 CRANK ASSEMBLY
- (C) 67A4C2Z1 NUT , LOCK
- (D) 12A5D9Z1 WASHER
- (E) 36870129 TUBE , OUTER
- (F) 36870079 BEARING , THRUST
- (G) 36870053 TUBE , INNER
- (H) 36870145 BASE
- (J) 35336700 NUT , LOCK
- (K) 36A2D281Z1 BOLT

JACK ASSEMBLY / PART NUMBER 36870111

|  |                              |                       |
|--|------------------------------|-----------------------|
| INGERSOLL-RAND COMPANY<br>PORTABLE COMPRESSOR DIVISION |                              |                       |
| DATE/DWN BY<br>2-00 WAP                                | DESCRIPTION<br>JACK ASSEMBLY |                       |
| MODEL NO<br>JD<br>DEUCE                                | MANUAL NO<br>35369823-6      | DATE/REV.<br>2-00 / B |



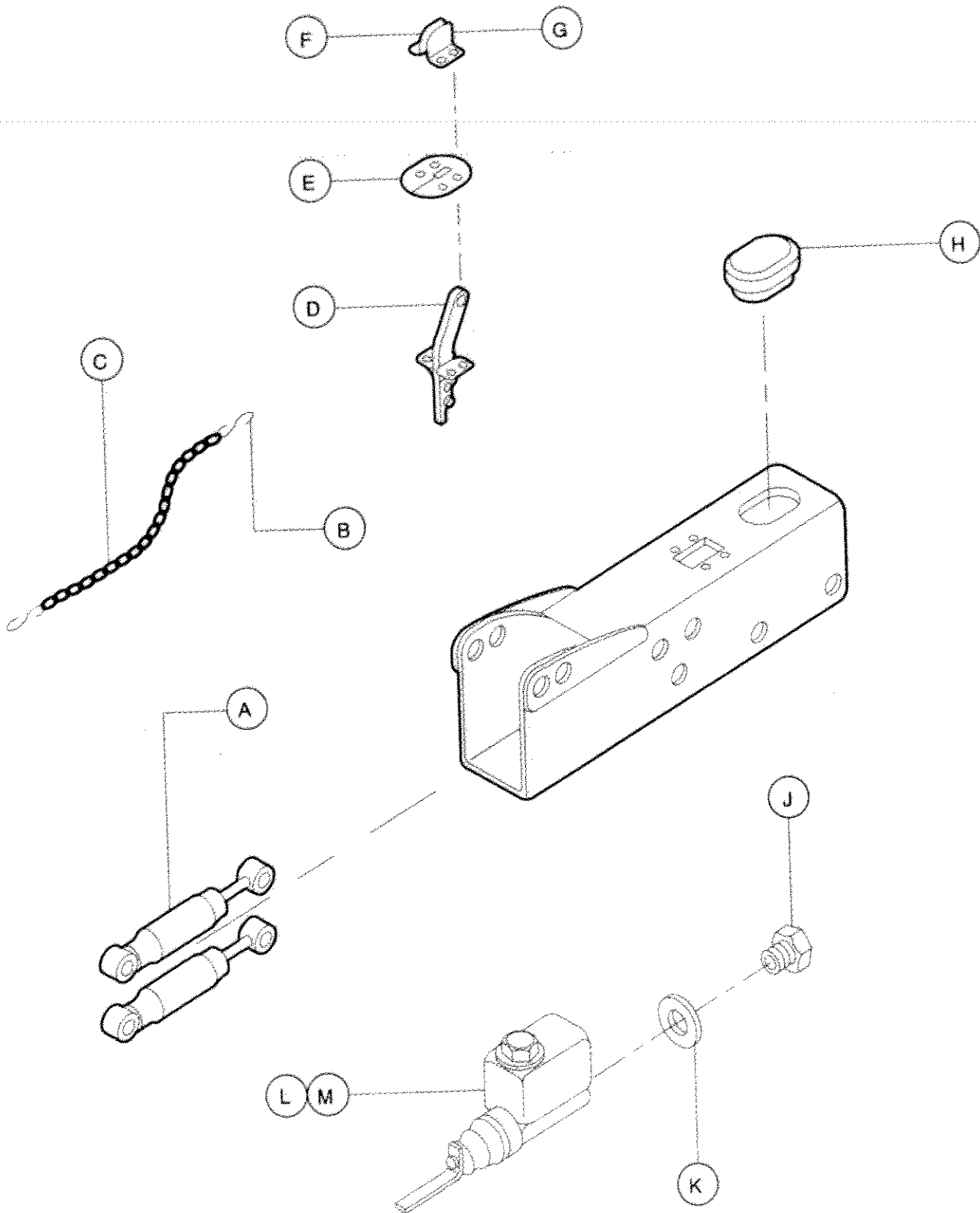

| INGERSOLL-RAND COMPANY<br>PORTABLE COMPRESSOR DIVISION |                         |           |
|--|-------------------------|-----------|
| DATE/CHK BY:   | DESCRIPTION:            |           |
| 2-00 WAP   | BRAKE ACTUATOR ASSEMBLY |           |
| MODEL NO.  | MANUAL NO.              | DATE/REV. |
| J0   | 35388923-7              | 2-00 / B  |
| DEVICE   |                         |           |

- (A) 36867582 DAMPER
- (B) 35373083 S-HOOK
- (C) 35373091 CHAIN
- (D) 35373042 LEVER ASSEMBLY
- (E) 35373059 SEAL , WEATHER
- (F) 35373067 LOCK , R.H.
- (G) 35373075 LOCK , L.H.
- (H) 35373034 COVER
- (J) 35373109 CONNECTOR
- (K) 35373125 GASKET
- (L) 35373117 MASTER CYLINDER
- (M) 35376433 REPAIR KIT

HYDRAULIC BRAKE ACTUATOR ASSEMBLY - PART NO. 36867299

|  |                         |           |  |
|--|-------------------------|-----------|--|
| INGERSOLL-RAND COMPANY<br>PORTABLE COMPRESSOR DIVISION |                         |           |  |
| DATE/DRAWN BY  | DESCRIPTION             |           |  |
| 2-00 WAP   | BRAKE ACTUATOR ASSEMBLY |           |  |
| MODEL NO.  | MANUAL NO.              | DATE/REV. |  |
| JD<br>DEUCE  | 35389923-8              | 2-00 / 8  |  |

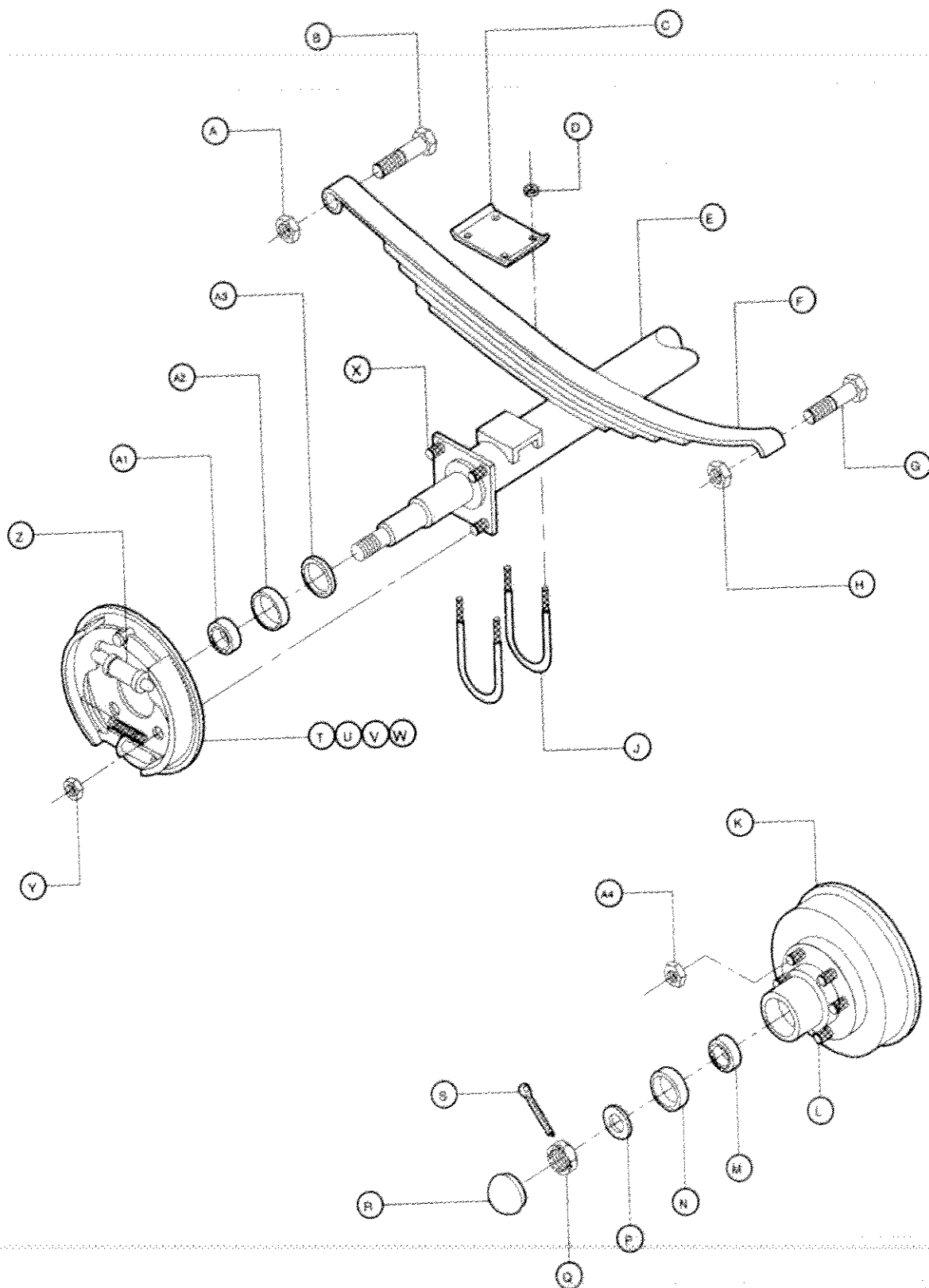

|   |     |                       |           |
|---|-----|-----------------------|-----------|
| <b>INGERSOLL-RAND COMPANY</b><br>PORTABLE COMPRESSOR DIVISION |     |                       |           |
| DATEOWN BY:   |     | DESCRIPTION           |           |
| 2-00  | WAP | RUNNING GEAR ASSEMBLY |           |
| MODEL NO.   |     | MATERIAL NO.          | DATE/REV. |
| JD  |     | 35389923-9            | 2-00 / 8  |
| DEUCE   |     |                       |           |

|     |          |                     |      |          |                            |
|-----|----------|---------------------|------|----------|----------------------------|
| (A) | 36784882 | NUT                 | (Q)  | 35315217 | NUT                        |
| (B) | 36784874 | BOLT                | (R)  | 36844637 | CAP , GREASE               |
| (C) | 36867820 | PLATE , TIE         | (S)  | 35315225 | PIN , COTTER               |
| (D) | 36867648 | NUT (4 REQD)        | (T)  | 36867681 | L.H. BRAKE ASSY. ( REAR )  |
| (E) | 36867588 | FRONT AXLE ASSEMBLY | (U)  | 36867679 | R.H. BRAKE ASSY. ( REAR )  |
|     | 36867653 | REAR AXLE ASSEMBLY  | (V)  | 36867596 | R.H. BRAKE ASSY. ( FRONT ) |
| (F) | 36867612 | SPRING              | (W)  | 36867604 | L.H. BRAKE ASSY. ( FRONT ) |
| (G) | 35315365 | BOLT                | (X)  | 36842177 | SCREW (4 REQD)             |
| (H) | 35315373 | NUT                 | (Y)  | 36842185 | NUT (4 REQD)               |
| (J) | 36867838 | U-BOLT (2 REQD)     | (Z)  | 36867851 | L.H. WHEEL CYLINDER        |
| (K) | 36842144 | HUB ASSEMBLY        |      | 36867885 | R.H. WHEEL CYLINDER        |
| (L) | 35385244 | STUD (6 REQD)       | (A1) | 36844694 | BEARING , INNER            |
| (M) | 36844652 | BEARING , OUTER     | (A2) | 36844686 | CUP , INNER                |
| (N) | 36844660 | CUP , OUTER         | (A3) | 36844702 | SEAL , GREASE              |
| (P) | 35315209 | WASHER              | (A4) | 35385251 | NUT (6 REQD)               |

36867869 BRAKE LINING KIT

36867877 BRAKE SPRING KIT

| INGERSOLL-RAND COMPANY<br>PORTABLE COMPRESSOR DIVISION |                           |                       |
|--|---------------------------|-----------------------|
| DATE/DWN BY:   | DESCRIPTION               |                       |
| 2-00 WAP   | RUNNING GEAR ASSEMBLY     |                       |
| MODEL NO.<br>JD<br>DEVICE                              | MANUAL NO.<br>35389923-10 | DATE/REV.<br>2-00 / B |

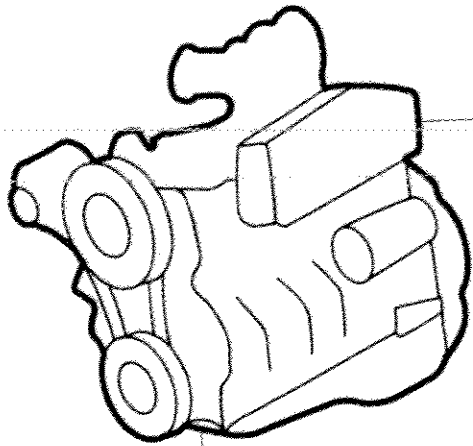

B1 B2 B3 B4 B5 B6 B7 B8

A4 A5 A6  
A7 A8 A9

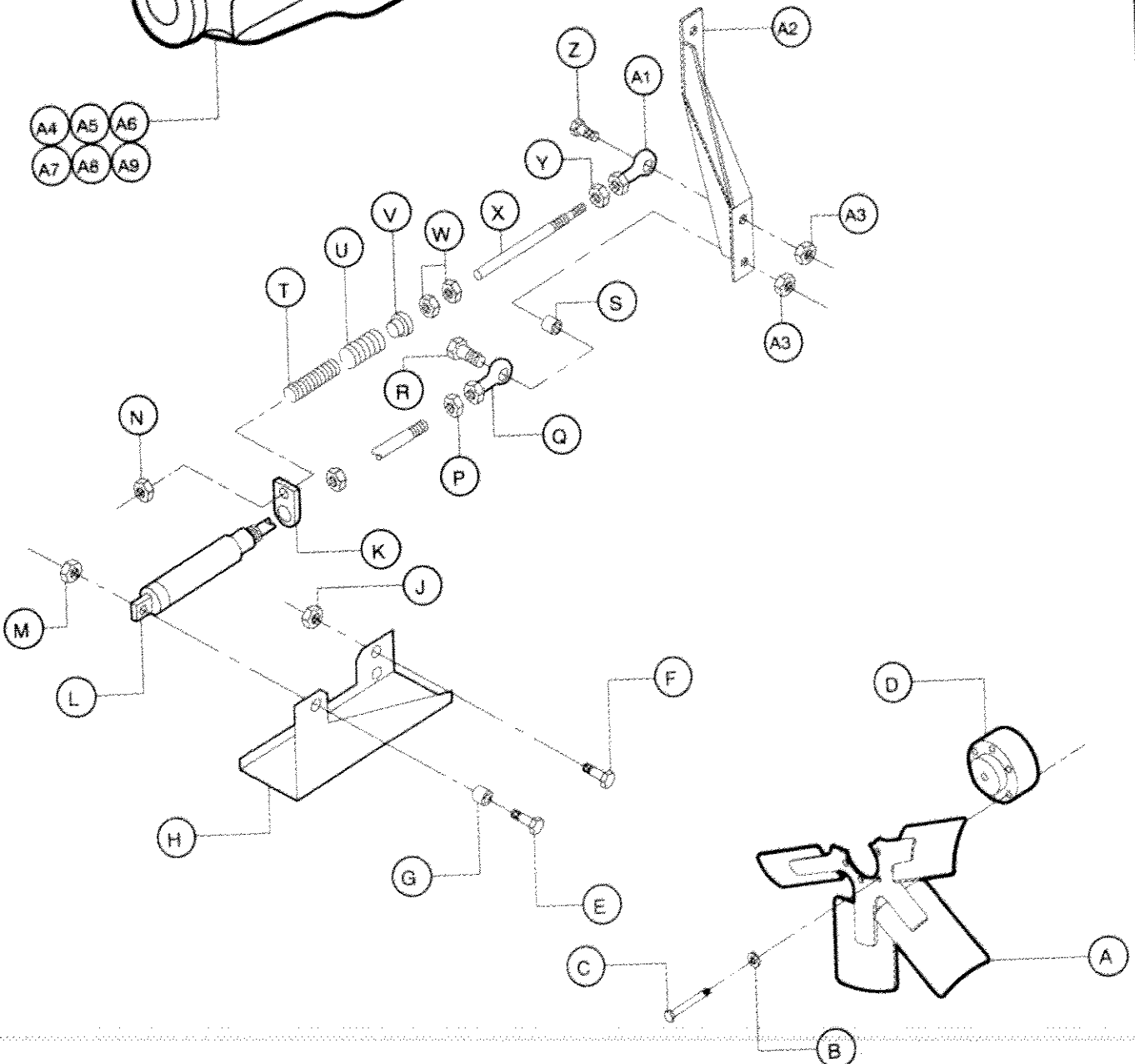

|  |   |                      |  |
|--|---|----------------------|--|
| INGERSOLL-RAND COMPANY<br>PORTABLE COMPRESSOR DIVISION |   |                      |  |
| DATE/DRAWN BY<br>2-00 WAP                              | DESCRIPTION<br>ENGINE AND SPEED CONTROL |                      |  |
| MODEL NO<br>JD<br>DEUCE                                | MANUAL NO<br>35389923-11                | DATE/REV<br>2-05 / A |  |

|     |             |  |      |             |   |
|-----|-------------|--|------|-------------|---|
| (A) | 3686626     | FAN, 36 INCH<br>(HP600WJD / XP750WJD)      | (Y)  | 23A4C3Z1    | NUT   |
|     | 36876480    | FAN, 36 INCH<br>(HP750WJD / XP825WJD)      | (Z)  | 34M2AB311M3 | SCREW   |
| (B) | 12M5L26M3   | WASHER (6 REQD)<br>(HP600WJD / XP750WJD)   | (A1) | 35322836    | BALL JOINT                                    |
|     | 12A504Z1    | WASHER (6 REQD)<br>(HP750WJD / XP825WJD)   | (A2) | 36869164    | LEVER, SPEED CONTROL<br>(HP600WJD / XP750WJD) |
| (C) | 35M2AB423M3 | SCREW (6 REQD)<br>(HP600WJD / XP750WJD)    |      | 36870731    | LEVER, SPEED CONTROL<br>(HP750WJD / XP825WJD) |
|     | 35A2D115Z1  | SCREW (6 REQD)<br>(HP750WJD / XP825WJD)    | (A3) | 16M4JC21M3  | NUT   |
| (D) | 36868883    | SPACER, FAN<br>(HP600WJD / XP750WJD)       | (A4) | 36865582    | MOUNT, ENGINE                                 |
|     | 36876506    | SPACER, FAN<br>(HP750WJD / XP825WJD)       | (A5) | 35A2D217Z1  | SCREW (4 REQD)                                |
| (E) | 36761476    | SCREW                                      | (A6) | 35302835    | MOUNT, RUBBER                                 |
| (F) | 34M2AB309   | SCREW (2 REQD)                             | (A7) | 35273937    | WASHER  |
| (G) | 35288885    | BUSHING                                    | (A8) | 35M2AB573M3 | SCREW   |
| (H) | 36868172    | BRACKET, MOUNTING<br>(HP600WJD / XP750WJD) | (A9) | 35356626    | NUT   |
|     | 36871671    | BRACKET, MOUNTING<br>(HP750WJD / XP825WJD) | (B1) | 36868368    | FITTING, WATER                                |
| (J) | 16M4JC21M3  | NUT (2 REQD)                               | (B2) | 36866556    | ENGINE, JD<br>(HP600WJD / XP750WJD)           |
| (K) | 35322445    | GUIDE, ROD                                 |      | 36876530    | ENGINE, JD<br>(HP750WJD / XP825WJD)           |
| (L) | 35594226    | CYLINDER, AIR                              | (B3) | 23A7S3Z1    | BUSHING                                       |
| (M) | 67A4C2Z1    | NUT  | (B4) | 35358043    | TAG, ENGINE DIPSTICK                          |
| (N) | 35324664    | COLLAR                                     | (B5) | 23A7S5Z1    | BUSHING<br>(HP750WJD / XP825WJD)              |
| (P) | 23A4C4Z1    | NUT  | (B6) | 35369511    | ADAPTER<br>(HP750WJD / XP825WJD)              |
| (Q) | 35300532    | BEARING, ROD                               | (B7) | 36870038    | FILTER, ENGINE OIL                            |
| (R) | 34M2AB311M3 | SCREW                                      | (B8) | 36875046    | FILTER, ENGINE FUEL<br>(HP600WJD / XP750WJD)  |
| (S) | 35322462    | BUSHING                                    |      | 36869657    | FILTER, ENGINE FUEL<br>(HP750WJD / XP825WJD)  |
| (T) | 35329721    | SPRING                                     | (B9) | 36868156    | ELEMENT, WATER                                |
| (U) | 35322411    | SPRING                                     |      |             |   |
| (V) | 35322437    | MOUNT, SPRING                              |      |             |   |
| (W) | 23A4C3Z1    | NUT (2 REQD)                               |      |             |   |
| (X) | 35322429    | ROD  |      |             |   |

| INGERSOLL-RAND COMPANY       |                          |           |
|------------------------------|--------------------------|-----------|
| PORTABLE COMPRESSOR DIVISION |                          |           |
| DATE/DOWN BY                 | DESCRIPTION              |           |
| 2-00 WAP                     | ENGINE AND SPEED CONTROL |           |
| MODEL NO.                    | MANUAL NO.               | DATE/REV. |
| JD DEUCE                     | 35389923-12              | 2-00 / A  |

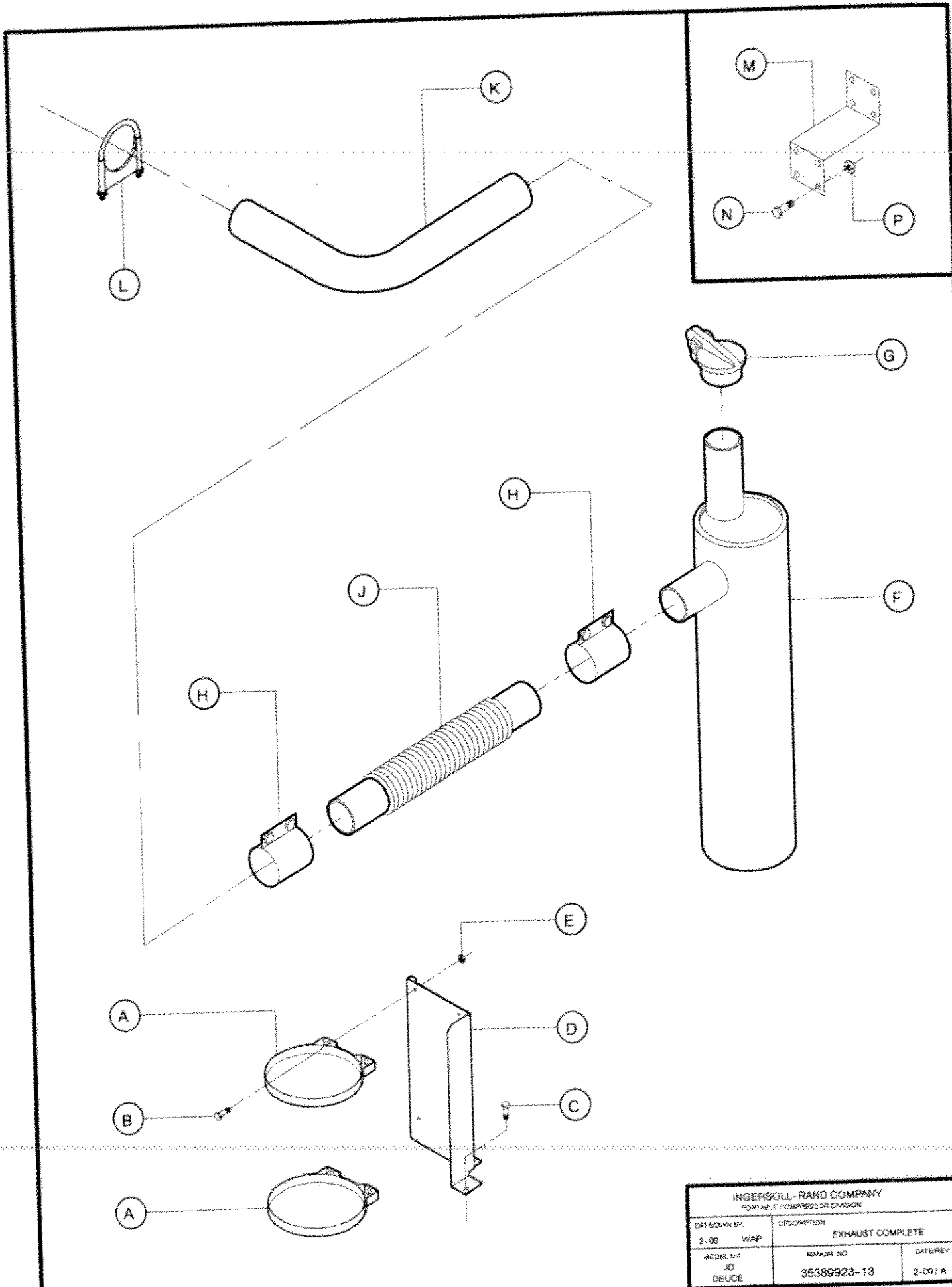

|  |                  |          |
|--|------------------|----------|
| INGERSOLL-RAND COMPANY<br>PORTABLE COMPRESSOR DIVISION |                  |          |
| DATE/OWN BY:   | DESCRIPTION      |          |
| 2-00 WAP   | EXHAUST COMPLETE |          |
| MODEL NO   | MANUAL NO        | DATE/REV |
| JD DEUCE   | 35389923-13      | 2-00 / A |

|     |            |                         |            |
|-----|------------|-------------------------|------------|
| (A) | 36866929   | BAND , MUFFLER MOUNTING |            |
| (B) | 35374842   | SCREW                   | ( 4 REQD ) |
| (C) | 35279025   | SCREW                   | ( 3 REQD ) |
| (D) | 36866937   | BRACKET , MUFFLER       |            |
| (E) | 16M4JC23M3 | NUT                     | ( 4 REQD ) |
| (F) | 36866911   | MUFFLER                 |            |
| (G) | 35857036   | CAP , RAIN              |            |
| (H) | 35313303   | SEALCLAMP               |            |
| (J) | 35602549   | PIPE , FLEX             |            |
| (K) | 36867133   | TUBE , EXHAUST          |            |
| (L) | 35111731   | CLAMP                   |            |
| (M) | 36868016   | BRACKET , TURBO         |            |
| (N) | 35271154   | SCREW                   | ( 4 REQD ) |
| (P) | 16M4JC24M3 | NUT                     | ( 4 REQD ) |

|  |                           |                    |  |
|--|---------------------------|--------------------|--|
| INGERSOLL-RAND COMPANY<br>PORTABLE COMPRESSOR DIVISION |                           |                    |  |
| DATE/DOWN BY   | DESCRIPTION               | EXHAUST COMPLETE   |  |
| 2-00 WAP   |                           |                    |  |
| MODEL NO.<br>JD<br>DEUCE                               | MANUAL NO.<br>35389923-14 | DATE/REV<br>2-06/A |  |



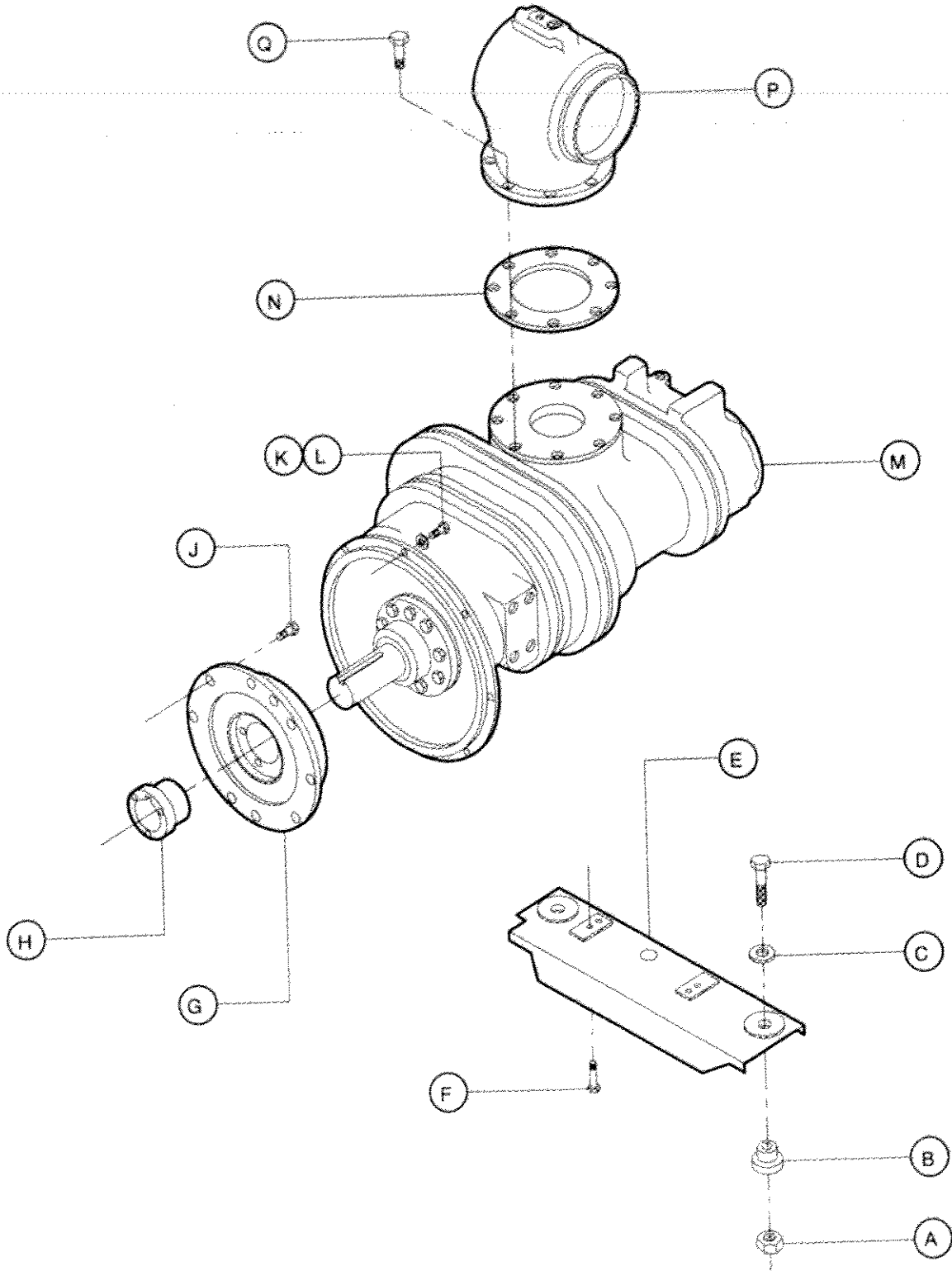

| INGERSOLL-RAND COMPANY<br>PORTABLE COMPRESSOR DIVISION |                  |          |
|--|------------------|----------|
| DATE/OWN BY:   | DESCRIPTION      |          |
| 2-00 WAP   | AIR END COMPLETE |          |
| MODEL NO.  | MANUAL NO.       | DATE/REV |
| JD<br>0EUC   | 35389923-15      | 2-00 / A |

|     |             |                            |             |
|-----|-------------|----------------------------|-------------|
| (A) | 35356526    | NUT                        | ( 2 REQD )  |
| (B) | 35302835    | MOUNT                      | ( 2 REQD )  |
| (C) | 35273937    | WASHER                     | ( 2 REQD )  |
| (D) | 35M2AB572M3 | SCREW                      | ( 2 REQD )  |
| (E) | 36865574    | BRACKET , AIR END MOUNTING |             |
| (F) | 35358274    | SCREW                      | ( 4 REQD )  |
| (G) | 35834787    | COUPLING , DRIVE           |             |
| (H) | 35103852    | BUSHING                    |             |
| (J) | 119A2A198N  | SCREW                      | ( 8 REQD )  |
| (K) | 35A2D113    | SCREW                      | ( 12 REQD ) |
| (L) | 14A5C76     | WASHER                     | ( 12 REQD ) |
| (M) | 36020766    | AIR END ASSEMBLY           |             |
| (N) | 36786572    | GASKET                     |             |
| (P) | 36734515    | UNLOADER ASSEMBLY          |             |
| (Q) | 35272558    | SCREW                      | ( 6 REQD )  |

### AIR END ASSEMBLY

————— 36020766

EXCHANGE AIREND OPTION: INGERSOLL-RAND OFFERS FACTORY REMANUFACTURED AIRENDS THAT ARE BUILT TO THE LATEST DESIGNS. MEANING IT WILL REFLECT ALL THE ENGINEERING UPGRADES AND PERFORMANCE ENHANCEMENTS MADE TO THAT SIZE UNIT. ALL EXCHANGE AIRENDS COME WITH A ONE YEAR WARRANTY. THESE BENEFITS MAKE A FACTORY REBUILT AIREND THE ONLY COST EFFECTIVE OPTION. CALL YOUR LOCAL IR DEALER FOR MORE DETAILS. PLEASE PROVIDE YOUR AIREND SERIAL NUMBER.

| INGERSOLL-RAND COMPANY<br>PORTABLE COMPRESSOR DIVISION |                                 |                      |
|--|---------------------------------|----------------------|
| DATE/DOWN BY:<br>2-00 WAP                              | DESCRIPTION<br>AIR END COMPLETE |                      |
| MODEL NO.<br>JD<br>DEUCE                               | MANUAL NO.<br>35389923-16       | DATE/REV<br>2-00 / A |

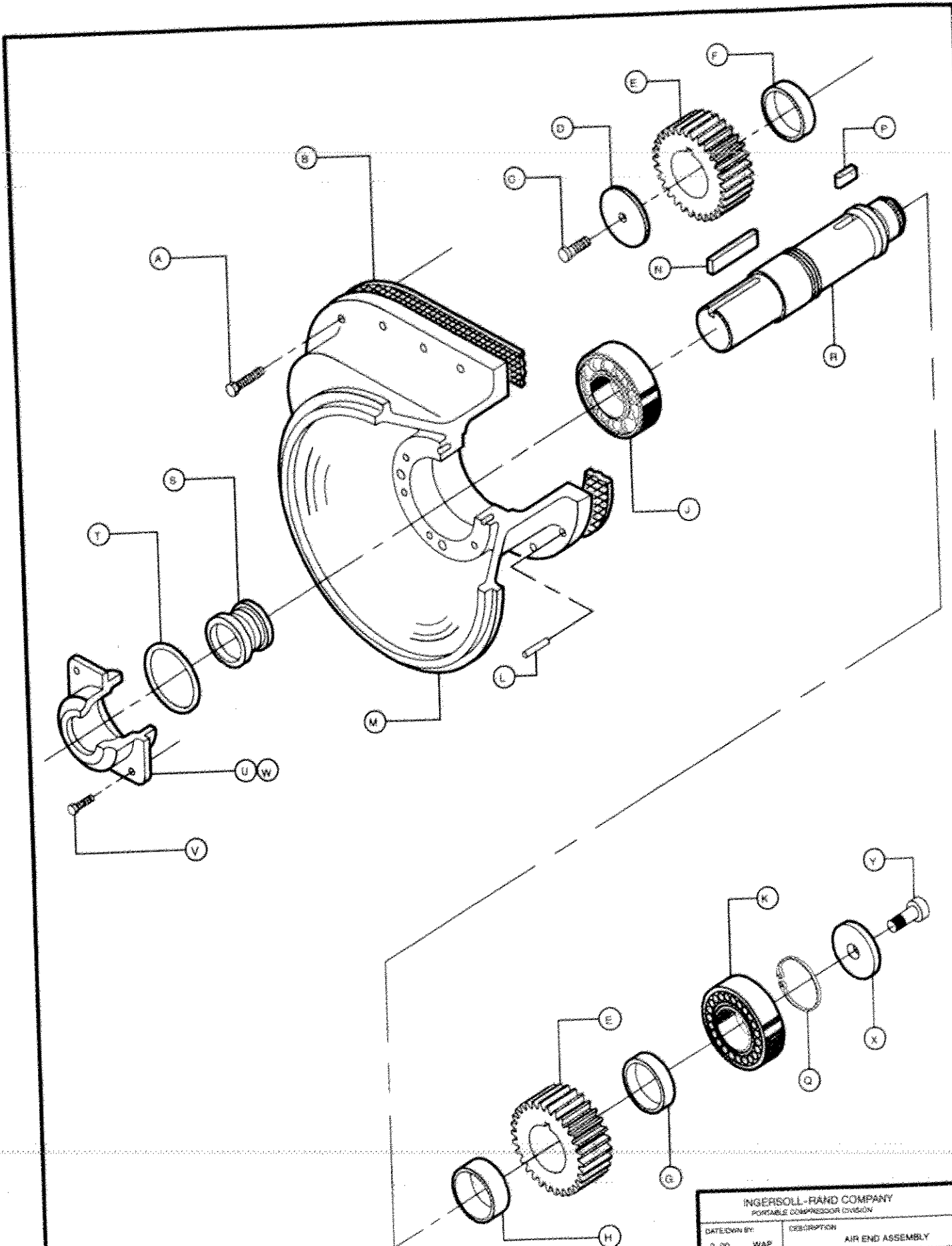

| INGERSOLL-RAND COMPANY<br>PORTABLE COMPRESSOR DIVISION |                  |          |  |
|--|------------------|----------|--|
| DATE/OWN BY:   | DESCRIPTION      |          |  |
| 2-00 WAP   | AIR END ASSEMBLY |          |  |
| MODEL NO.  | MANUAL NO.       | DATE/REV |  |
| JD<br>DEUCE  | 35389923-17      | 2-00 / A |  |

STARTS AT SERIAL NO.

297429

- (A) 35272541 SCREW (14 REQD)
- (B) 35811388 GASKET
- (C) 34M2AB512 SCREW
- (D) 35255819 PLATE, CLAMP
- (E) GEAR SET NO. UNIT
 

|          |                            |          |                            |
|----------|----------------------------|----------|----------------------------|
| 35298132 | XP-750-W-CU<br>XP-750-W-JD | 35334853 | XP-825-W-CU<br>XP-825-W-JD |
| 35303742 | HP-800-X-CU<br>HP-800-W-JD | 35335383 | HP-750-W-CU<br>HP-750-W-JD |
- (F) 35299346 SPACER
- (G) 36851681 SPACER
- (H) 36846418 SPACER
- (J) 36846426 BEARING, TAPERED ROLLER
- (K) 36854925 BEARING, TAPERED ROLLER
- (L) 17A13A289 PIN, DOWEL
- (M) 36851459 CASE, GEAR
- (N) 35364975 KEY
- (P) 35381328 KEY
- (Q) 95223145 RING, RETAINING
- (R) 36846400 SHAFT, DRIVE
- (S) 35593508 SEAL, SHAFT
- (T) 20A11C2M252 O-RING
- (U) 36507515 COVER
- (V) 34M2AB462 SCREW (6 REQD)
- (W) 36846442 SHIM
- (X) 36784785 CAP
- (Y) 35336304 SCREW

|                              |             |                  |  |
|------------------------------|-------------|------------------|--|
| INGERSOLL-RAND COMPANY       |             |                  |  |
| PORTABLE COMPRESSOR DIVISION |             |                  |  |
| DATE DRAWN BY:               |             | DESCRIPTION      |  |
| 2-00                         | WAP         | AIR END ASSEMBLY |  |
| MODEL NO.                    | MANUAL NO.  | DATE REV.        |  |
| JD                           | 35389923-18 | 2-00 / A         |  |
| DEVICE                       |             |                  |  |

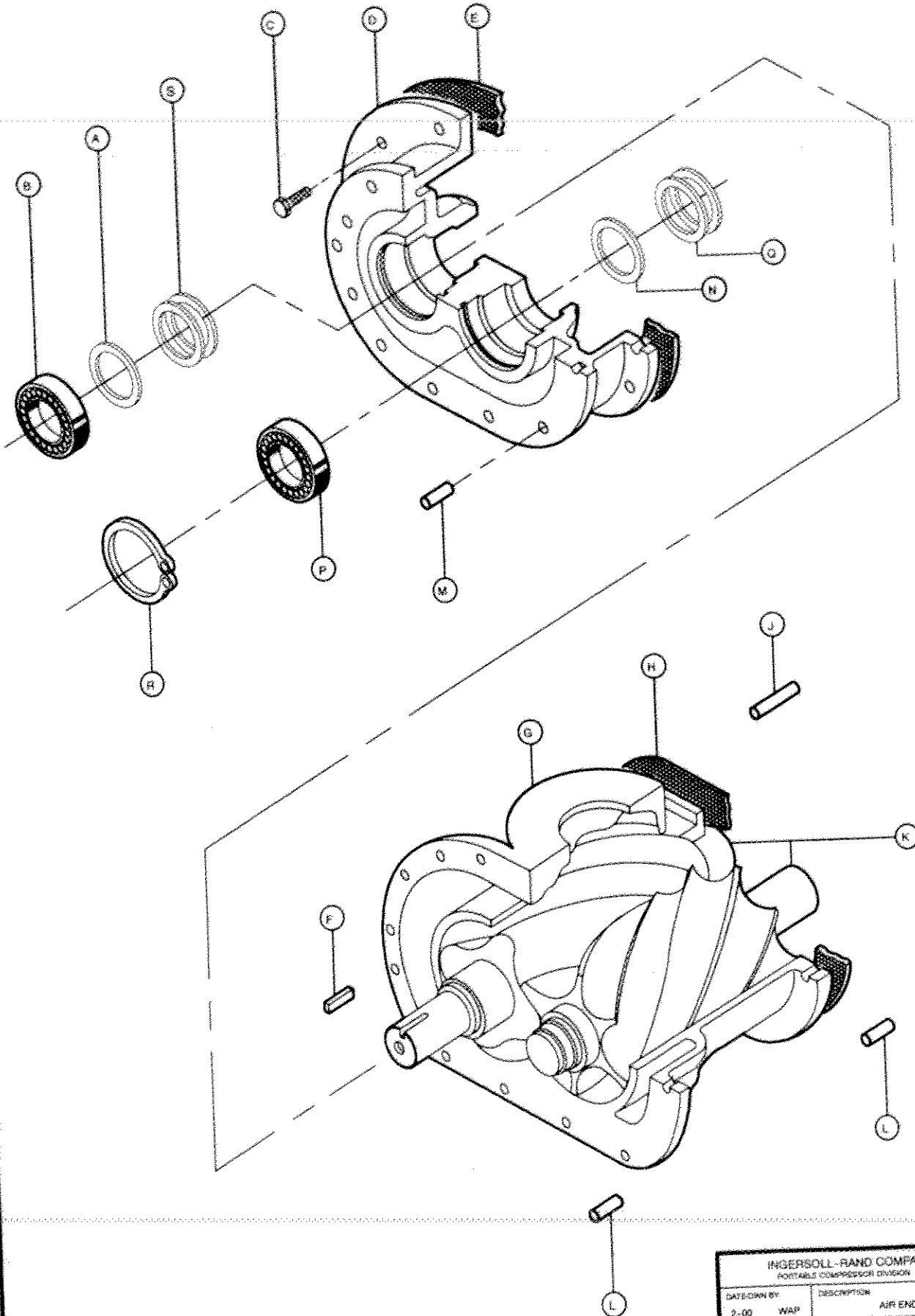

|  |                                 |                       |
|--|---------------------------------|-----------------------|
| INGERSOLL-RAND COMPANY<br>PORTABLE COMPRESSOR DIVISION |                                 |                       |
| DATE-DRAWN BY:<br>2-00 WAP                             | DESCRIPTION<br>AIR END ASSEMBLY |                       |
| MODEL NO.<br>JD<br>GEUCE                               | MANUAL NO.<br>35389923-19       | CATEGORY:<br>2-00 / A |

- (A) 35299296 SPACER
- (B) 35299262 BEARING , ROLLER
- (C) 35272541 SCREW ( 17 REQD )
- (D) 36711620 HOUSING , FRONT BEARING
- (E) 36506699 GASKET
- (F) 35361310 KEY
- (G) 36794287 HOUSING , ROTOR
- (H) 35611342 GASKET
- (J) 17A13A289 PIN , LOCATING
- (K) 36005023 ROTOR SET
- (L) 35365261 PIN , LOCATING
- (M) 35365261 PIN , LOCATING
- (N) 35299312 SPACER
- (P) 35299270 BEARING , ROLLER
- (Q) 35364728 SPRING SET
- (R) 35299338 RING , SNAP
- (S) 35364710 SPRING , SET

| INGERSOLL-RAND COMPANY<br>PORTABLE COMPRESSOR DIVISION |                           |                       |  |
|--|---------------------------|-----------------------|--|
| DATE/DRAWN BY:   | DESCRIPTION               |                       |  |
| 2-08 WAP   | AIR END ASSEMBLY          |                       |  |
| MODEL NO.<br>JD<br>DEUCE                               | MANUAL NO.<br>35389923-20 | DATE/REV.<br>2-00 / A |  |

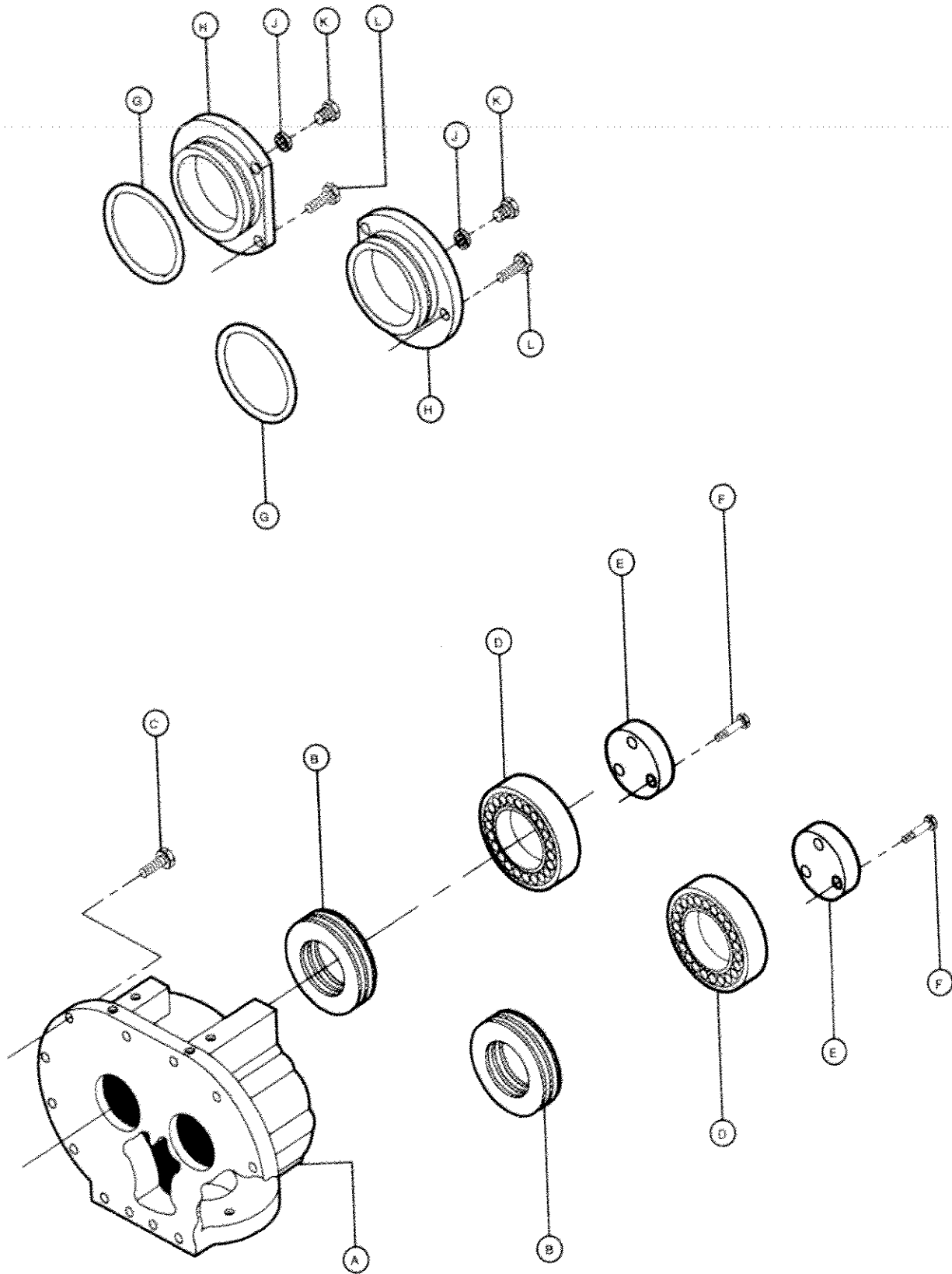

| INGERSOLL-RAND COMPANY<br>PORTABLE COMPRESSOR DIVISION |                          |                      |
|--|--------------------------|----------------------|
| DATE DRAWN BY  | DESCRIPTION              |                      |
| 2-00 WAP   | AIR END ASSEMBLY         |                      |
| MODEL NO<br>JD<br>DEUCE                                | MANUAL NO<br>35389923-21 | DATE REV<br>2-00 / A |

|     |           |                        |
|-----|-----------|------------------------|
| (A) | 36713881  | HOUSING , REAR BEARING |
| (B) | 35299361  | SHIM SET               |
| (C) | 34M2AB565 | SCREW ( 16 REQD )      |
| (D) | 35299254  | BEARING , ROLLER       |
| (E) | 35299320  | PLATE , CLAMP          |
| (F) | 35293869  | SCREW ( 6 REQD )       |
| (G) | 95358198  | O-RING                 |
| (H) | 35579309  | COVER , REAR BEARING   |
| (J) | 35278555  | PLUG                   |
| (K) | 35272533  | SCREW ( 6 REQD )       |

|  |             |                  |  |
|--|-------------|------------------|--|
| INGERSOLL-RAND COMPANY<br>PORTABLE COMPRESSOR DIVISION |             |                  |  |
| DATE/REV BY:   |             | DESCRIPTION      |  |
| 2-00   | WAP         | AIR END ASSEMBLY |  |
| MODEL NO.  | MANUAL NO.  | DATE/REV.        |  |
| JD<br>DEUCE  | 35389923-22 | 2-00 / A         |  |



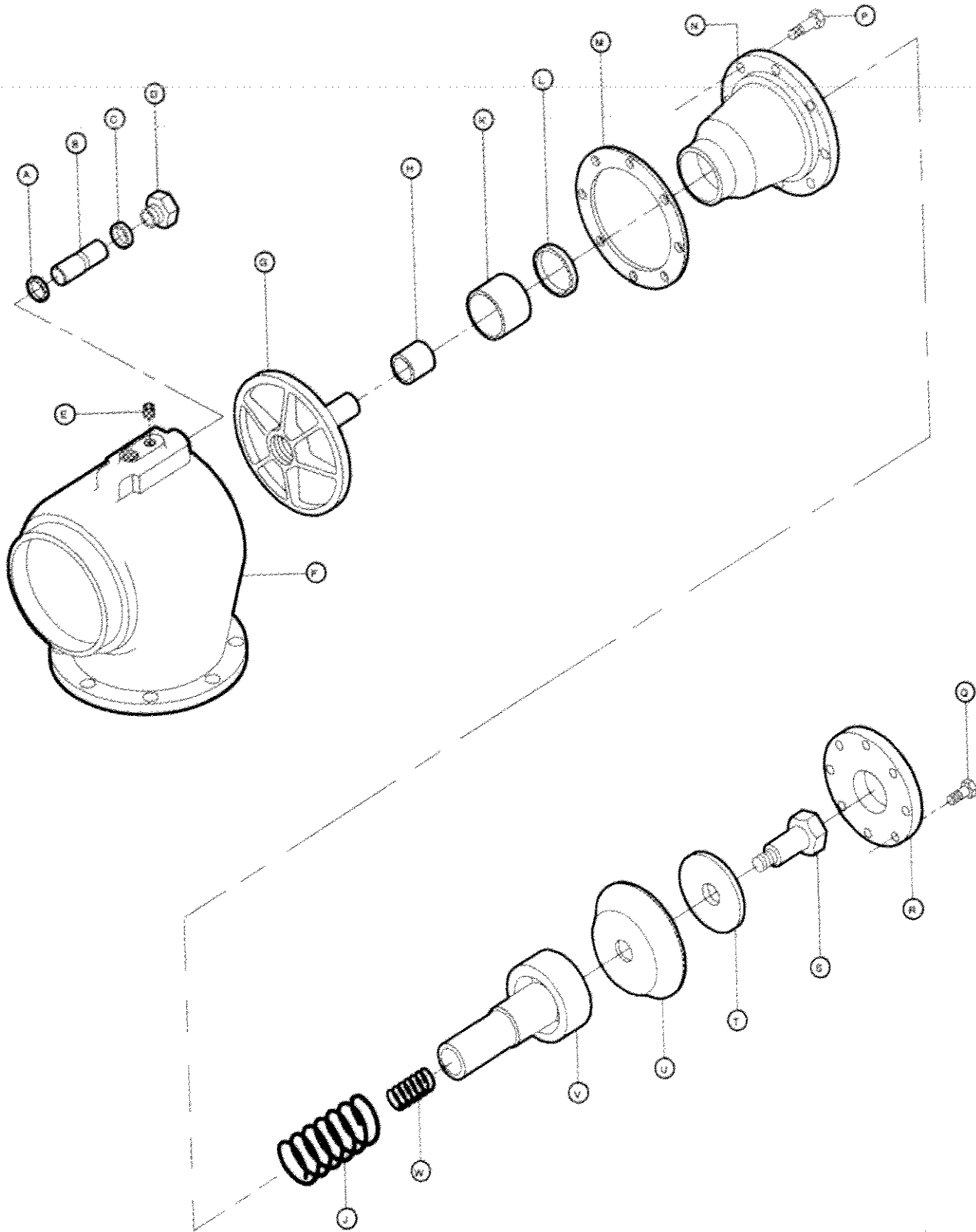

|  |                                  |                      |
|--|----------------------------------|----------------------|
| INGERSOLL-RAND COMPANY<br>PORTABLE COMPRESSOR DIVISION |                                  |                      |
| DATE/DWN BY:<br>2-00 WAP                               | DESCRIPTION<br>UNLOADER ASSEMBLY |                      |
| MODEL NO.<br>JO<br>DEUCE                               | MANUAL NO.<br>35389923-23        | DATE/REV<br>2-00 / A |

- (A) 35331586 GROMMET
- (B) 35328210 VALVE
- (C) 35331578 GROMMET
- (D) 35328236 ADAPTER
- (E) 34A785 PLUG
- (F) 36734507 BODY
- (G) 35597508 VALVE ASSEMBLY
- (H) 35328269 BUSHING ( 2 REQD )
- (J) 35332691 SPRING
- (K) 35328228 BUSHING
- (L) 35328244 SEAL
- (M) 35328251 GASKET
- (N) 36722480 HOUSING
- (P) 35271188 SCREW ( 12 REQD )
- (Q) 35273416 SCREW ( 8 REQD )
- (R) 35591189 COVER , PISTON
- (S) 35A2D217 SCREW
- (T) 35327204 WASHER
- (U) 35592534 DIAPHRAGM
- (V) 35591163 PISTON
- (W) 35332683 SPRING

UNLOADER ASSEMBLY  
PART NO. 36734515

|  |                           |                      |
|--|---------------------------|----------------------|
| INGERSOLL-RAND COMPANY<br>PORTABLE COMPRESSOR DIVISION |                           |                      |
| DATE/DOWN BY:  | DESCRIPTION               |                      |
| 2-00 WAP   | UNLOADER ASSEMBLY         |                      |
| MODEL NO.<br>JD<br>DEUCE                               | SERIAL NO.<br>35389923-24 | DATE/REV<br>2-00 / A |

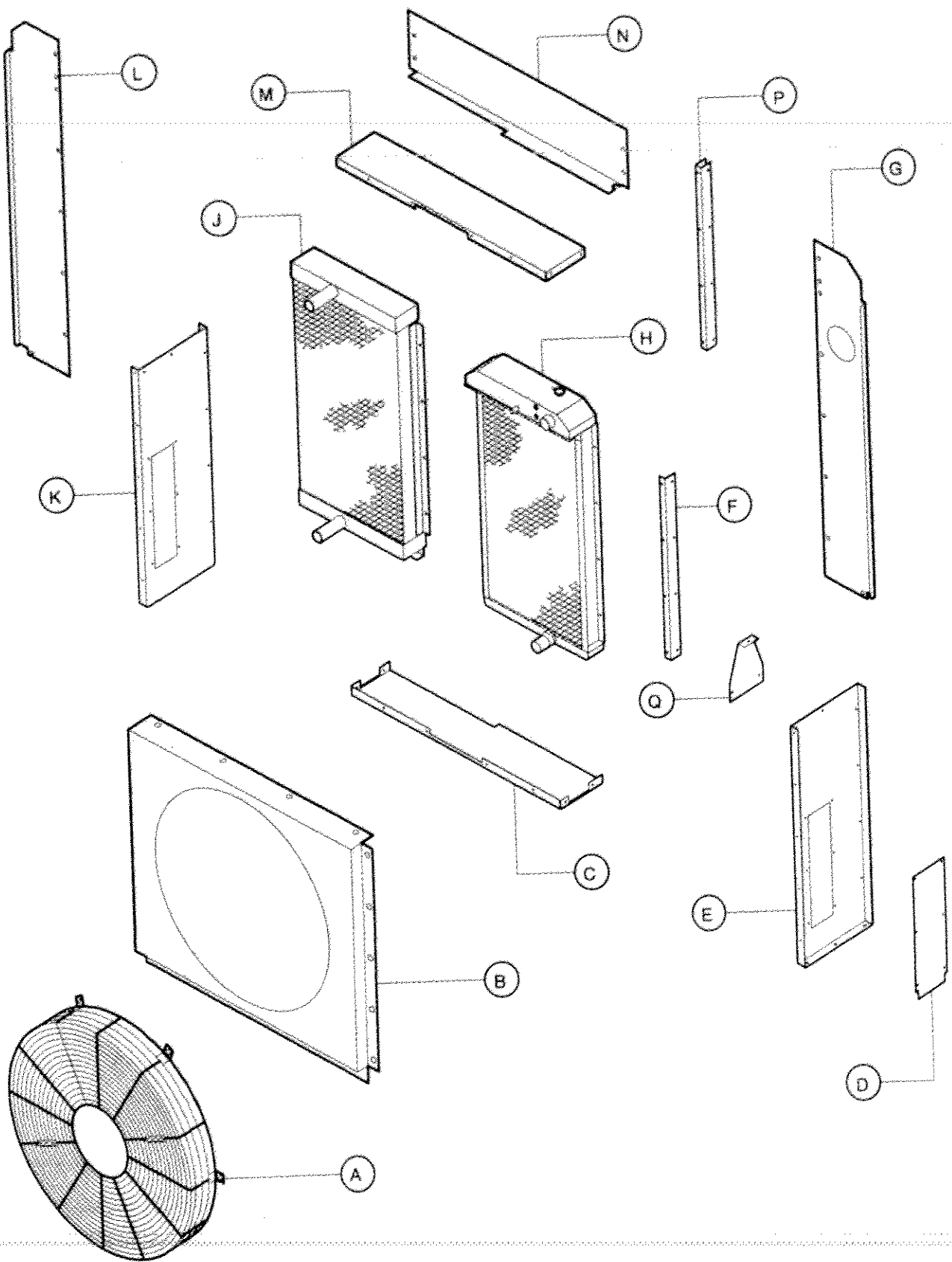

|  |   |                      |
|--|---|----------------------|
| INGERSOLL-RAND COMPANY<br>PORTABLE COMPRESSOR DIVISION |   |                      |
| DATE/AMN BY<br>2-05 WAP                                | DESCRIPTION<br>RADIATOR & OIL COOLER COMPLETE |                      |
| MODEL NO<br>JD<br>DEUCE                                | MANUAL NO.<br>35389923-25                     | DATE/REV<br>2-00 / A |

|     |          |                           |                                    |
|-----|----------|---------------------------|------------------------------------|
| (A) | 36866408 | GUARD , FAN               |                                    |
| (B) | 36866390 | ORIFICE , FAN             |                                    |
| (C) | 36866374 | SHROUD , BOTTOM COOLER    |                                    |
| (D) | 36868412 | COVER , ACCESS            |                                    |
| (E) | 36866358 | CHANNEL , RADIATOR SIDE   |                                    |
| (F) | 36868420 | ANGLE , RADIATOR MOUNTING |                                    |
| (G) | 36868438 | BAFFLE , L.H. REAR        |                                    |
| (H) | 36866192 | RADIATOR                  | ( HP600WJD / XP750WJD )            |
|     | 36877280 | RADIATOR                  | ( HP750WJD / XP825WJD )            |
| (J) | 36866200 | COOLER , OIL              |                                    |
| (K) | 36866366 | CHANNEL , OIL COOLER SIDE |                                    |
| (L) | 36868446 | BAFFLE , R.H. REAR        |                                    |
| (M) | 36866382 | SHROUD , TOP COOLER       |                                    |
| (N) | 36868453 | BAFFLE , REAR TOP         |                                    |
| (P) | 36877454 | SUPPORT , OIL COOLER      | ( HP750WJD / XP825WJD )            |
| (Q) | 36891331 | BRACKET , SUPPORT         | ( 2 REQD ) ( HP600WJD / XP750WJD ) |
|     | 36891364 | BRACKET , SUPPORT         | L.H. ( HP750WJD / XP825WJD )       |
|     | 36891372 | BRACKET , SUPPORT         | R.H. ( HP750WJD / XP825WJD )       |

| INGERSOLL-RAND COMPANY<br>PORTABLE COMPRESSOR DIVISION |   |                       |
|--|---|-----------------------|
| DATE/DOWN BY<br>2-00 WAP                               | DESCRIPTION<br>RADIATOR & OIL COOLER COMPLETE |                       |
| MODEL NO.<br>JD<br>DEUCE                               | MANUAL NO.<br>35389923-26                     | DATE/REV.<br>2-00 / A |

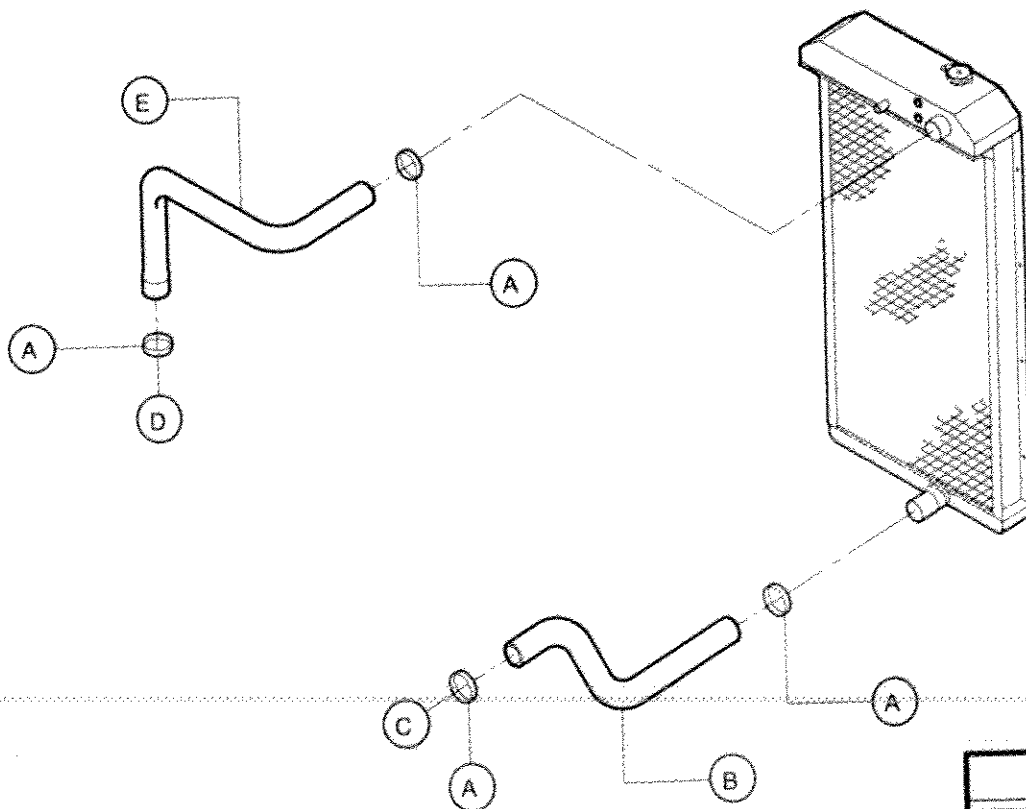
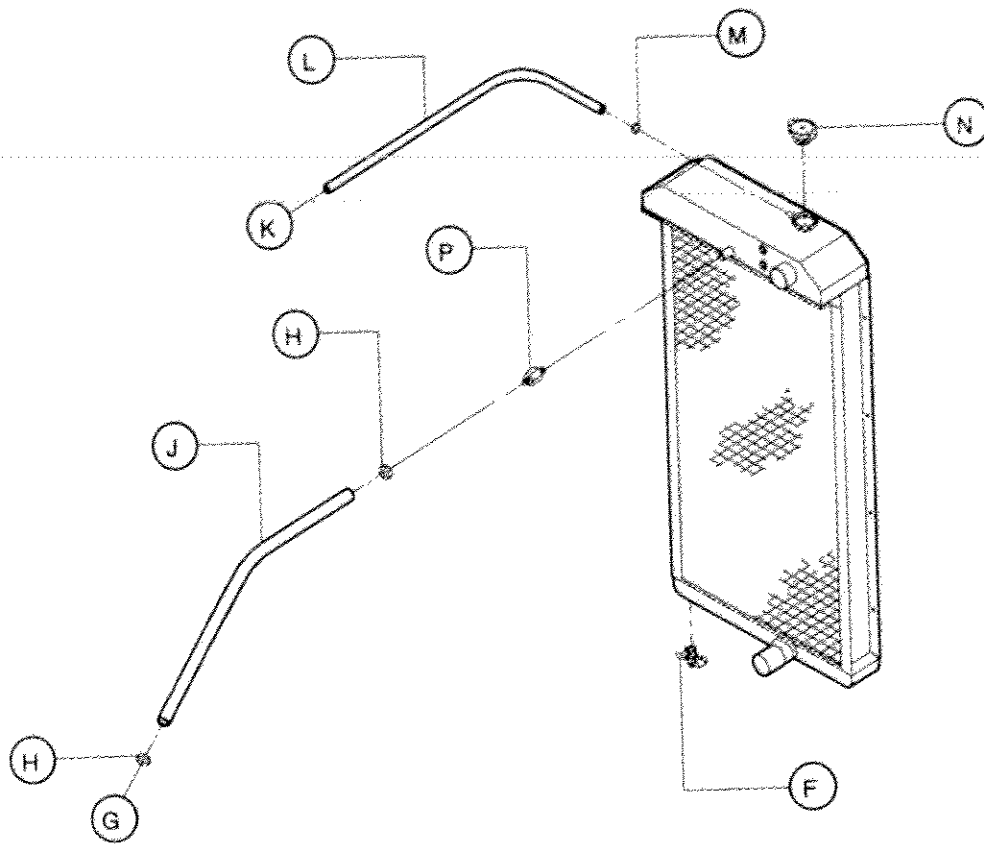

| INGERSOLL-RAND COMPANY<br>PORTABLE COMPRESSOR DIVISION |                                |                       |
|--|--------------------------------|-----------------------|
| DATE DRAWN BY:<br>2-00 WAP                             | DESCRIPTION<br>RADIATOR PIPING |                       |
| MODEL NO.<br>JD<br>DEUCE                               | MANUAL NO.<br>35389923-27      | DATE REV.<br>2-00 / A |

- (A) W86719 CLAMP
- (B) 36868107 HOSE , LOWER RADIATOR ( HP600WJD / XP750WJD )
- 36877314 HOSE , LOWER RADIATOR ( HP750WJD / XP825WJD )
- (C) TO ENGINE WATER INLET
- (D) TO ENGINE WATER OUTLET
- (E) 36868099 HOSE , UPPER RADIATOR ( HP600WJD / XP750WJD )
- 36877306 HOSE , UPPER RADIATOR ( HP750WJD / XP825WJD )
- (F) X1086T129 DRAIN COCK ( HP600WJD / XP750WJD )
- 67A7M2Z1 ELBOW ( HP750WJD / XP825WJD )
- 36782167 DRAIN COCK ( HP750WJD / XP825WJD )
- (G) TO ENGINE WATER PUMP
- (H) 122A23S16 CLAMP
- (J) 35286327 HOSE ( 44 INCHES ) ( HP600WJD / XP750WJD )
- 35286772 HOSE ( 39 INCHES ) ( HP750WJD / XP825WJD )
- (K) THROUGH BELLY PAN
- (L) 35360775 TUBING ( 66 INCHES )
- (M) 36845592 CLAMP
- (N) FURNISHED WITH RADIATOR
- (P) 35369511 ADAPTER ( HP750WJD / XP825WJD )

| INGERSOLL-RAND COMPANY<br>PORTABLE COMPRESSOR DIVISION |             |                 |  |
|--|-------------|-----------------|--|
| DATE/DOWN BY:  |             | DESCRIPTION     |  |
| 2-00   | WAP         | RADIATOR PIPING |  |
| MODEL NO.  | MANUAL NO.  | DATE/REV        |  |
| JO<br>DEUCE  | 35389923-28 | 2-00 / A        |  |

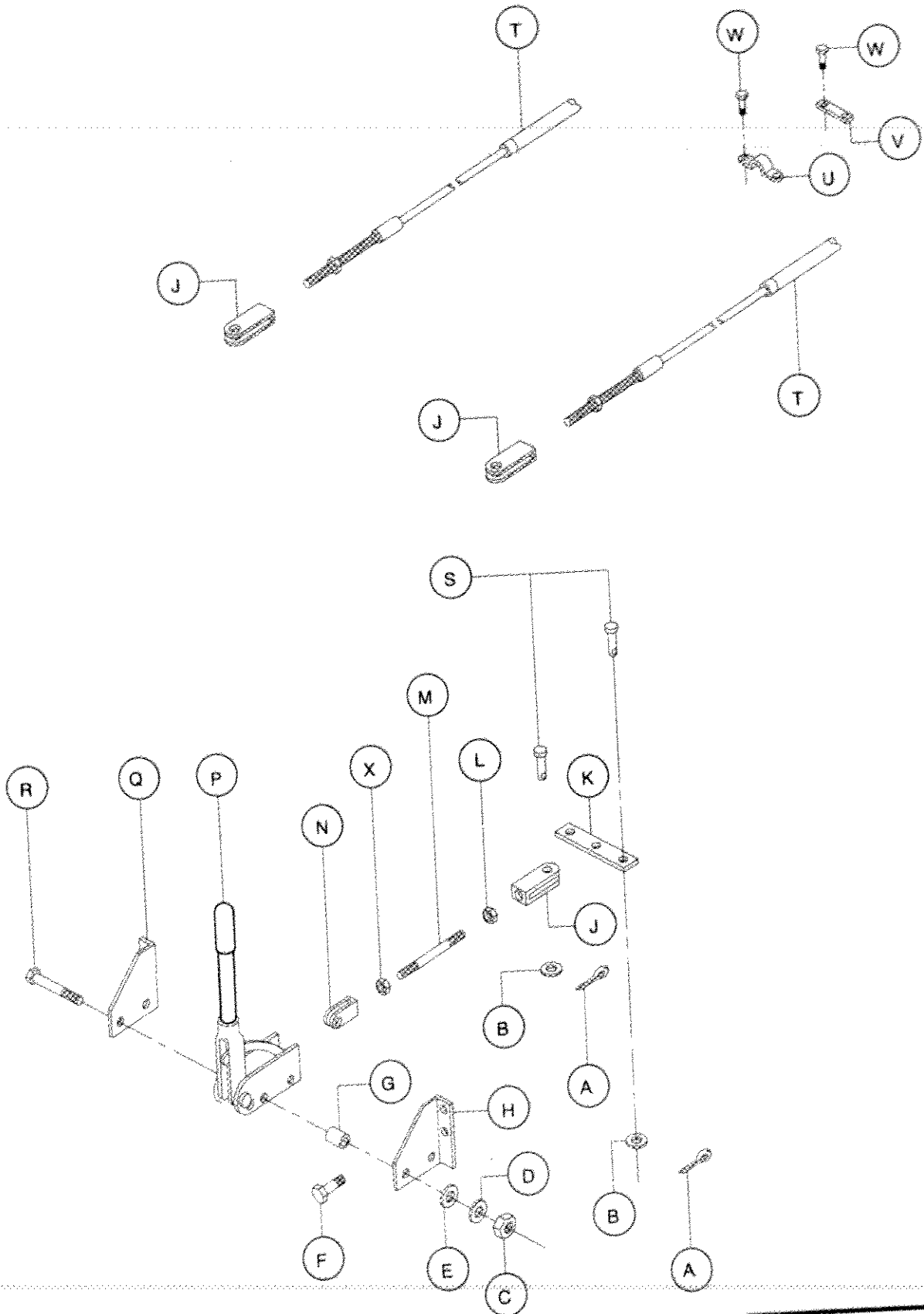

|                              |     |                |           |
|------------------------------|-----|----------------|-----------|
| INGERSOLL-RAND COMPANY       |     |                |           |
| PORTABLE COMPRESSOR DIVISION |     |                |           |
| DATE/REV. BY:                |     | DESCRIPTION    |           |
| 2-06                         | WAP | PARKING BRAKES |           |
| MODEL NO.                    |     | MANUAL NO.     | DATE/REV. |
| JD                           |     | 35389923-29    | 2-06 / A  |
| DEUCE                        |     |                |           |

|     |          |                |
|-----|----------|----------------|
| (A) | 95211900 | PIN , COTTER   |
| (B) | 11A5C3   | WASHER         |
| (C) | 92304526 | NUT            |
| (D) | 92304674 | WASHER         |
| (E) | 12A5C4   | WASHER         |
| (F) | 35272533 | SCREW          |
| (G) | 35603224 | SPACER         |
| (H) | 36847440 | BRACKET , L.H. |
| (J) | 35603208 | CLEVIS         |
| (K) | 35602846 | BRACKET        |
| (L) | 35118728 | NUT            |
| (M) | 35603182 | ROD , LINK     |
| (N) | 35603216 | CLEVIS         |
| (P) | 35857382 | LEVER          |
| (Q) | 36847432 | BRACKET , R.H. |
| (R) | 35295013 | SCREW          |
| (S) | 35357151 | PIN            |
| (T) | 35857408 | CABLE          |
| (U) | 35602895 | CLIP           |
| (V) | 35602903 | SPACER         |
| (W) | 35279025 | SCREW          |
| (X) | 22A4C2   | NUT            |

| INGERSOLL-RAND COMPANY<br>PORTABLE COMPRESSOR DIVISION |                           |                       |  |
|--|---------------------------|-----------------------|--|
| DATE/OWN BY  |                           | DESCRIPTION           |  |
| 2-00 WAP   |                           | PARKING BRAKES        |  |
| MODEL NO.<br>JD<br>DEUCE                               | MANUAL NO.<br>35389923-30 | DATE/REV.<br>2-00 / A |  |



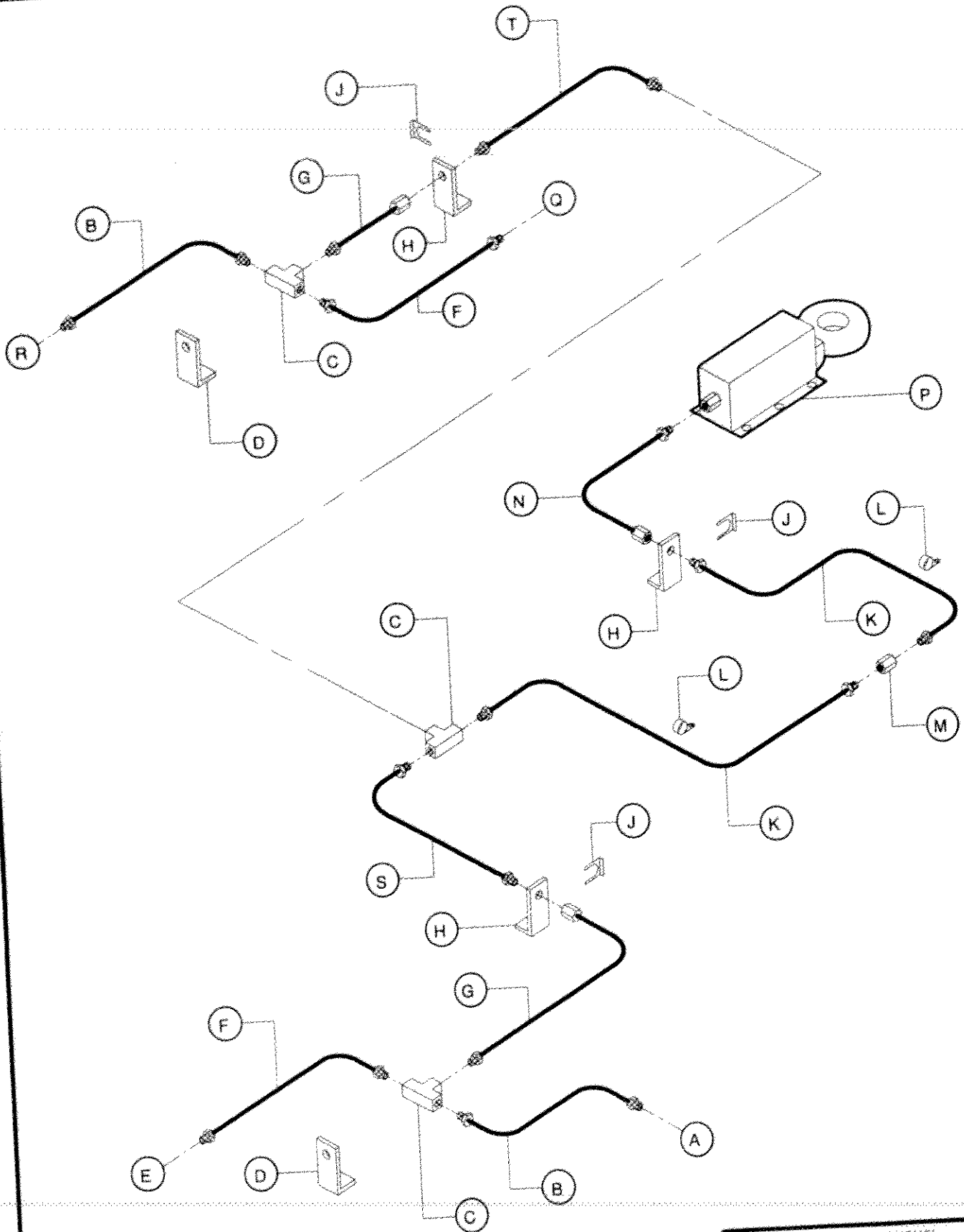

| INGERSOLL-RAND COMPANY<br>PORTABLE COMPRESSOR DIVISION |     |                           |                      |
|--|-----|---------------------------|----------------------|
| DATE/DOWN BY:  |     | DESCRIPTION               |                      |
| 2-06   | WAP | BRAKE LINE PIPING         |                      |
| MODEL NO.<br>JD<br>DEUCE                               |     | MANUAL NO.<br>35389923-31 | DATE/REV<br>2-00 / A |

|     |                           |                         |               |
|-----|---------------------------|-------------------------|---------------|
| (A) | TO L.H. SIDE / REAR AXLE  |                         |               |
| (B) | 36867281                  | TUBE ASSEMBLY           | ( 65 INCHES ) |
| (C) | 35356328                  | TEE                     |               |
| (D) | 36867471                  | BRACKET , TEE           |               |
| (E) | TO R.H. SIDE / REAR AXLE  |                         |               |
| (F) | 36867489                  | TUBE ASSEMBLY           |               |
| (G) | 35356377                  | HOSE , FLEX             |               |
| (H) | 35356310                  | BRACKET , HOSE MOUNTING |               |
| (J) | 35356302                  | CLIP , HOSE             |               |
| (K) | 35356401                  | TUBE ASSEMBLY           | ( 40 INCHES ) |
| (L) | X1182T23                  | CLAMP , TUBE            |               |
| (M) | 35356336                  | UNION                   |               |
| (N) | 35356369                  | HOSE , FLEX             |               |
| (P) | 36867299                  | BRAKE ACTUATOR ASSEMBLY |               |
| (Q) | TO R.H. SIDE / FRONT AXLE |                         |               |
| (R) | TO L.H. SIDE / FRONT AXLE |                         |               |
| (S) | 36876209                  | TUBE ASSEMBLY           |               |
| (T) | 36867273                  | TUBE ASSEMBLY           |               |

|  |             |                   |  |
|--|-------------|-------------------|--|
| INGERSOLL-RAND COMPANY<br>PORTABLE COMPRESSOR DIVISION |             |                   |  |
| DATE/OWN BY:   |             | DESCRIPTION       |  |
| 2-00   | WAP         | BRAKE LINE PIPING |  |
| MODEL NO.  | MANUAL NO.  | DATE/REV.         |  |
| JD<br>DEUCE  | 35389923-32 | 2-00 / A          |  |

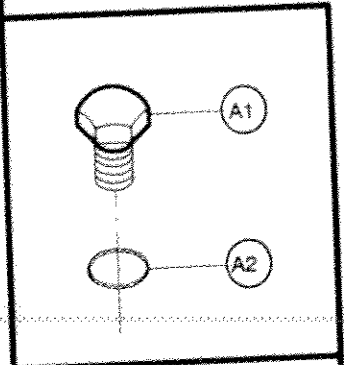
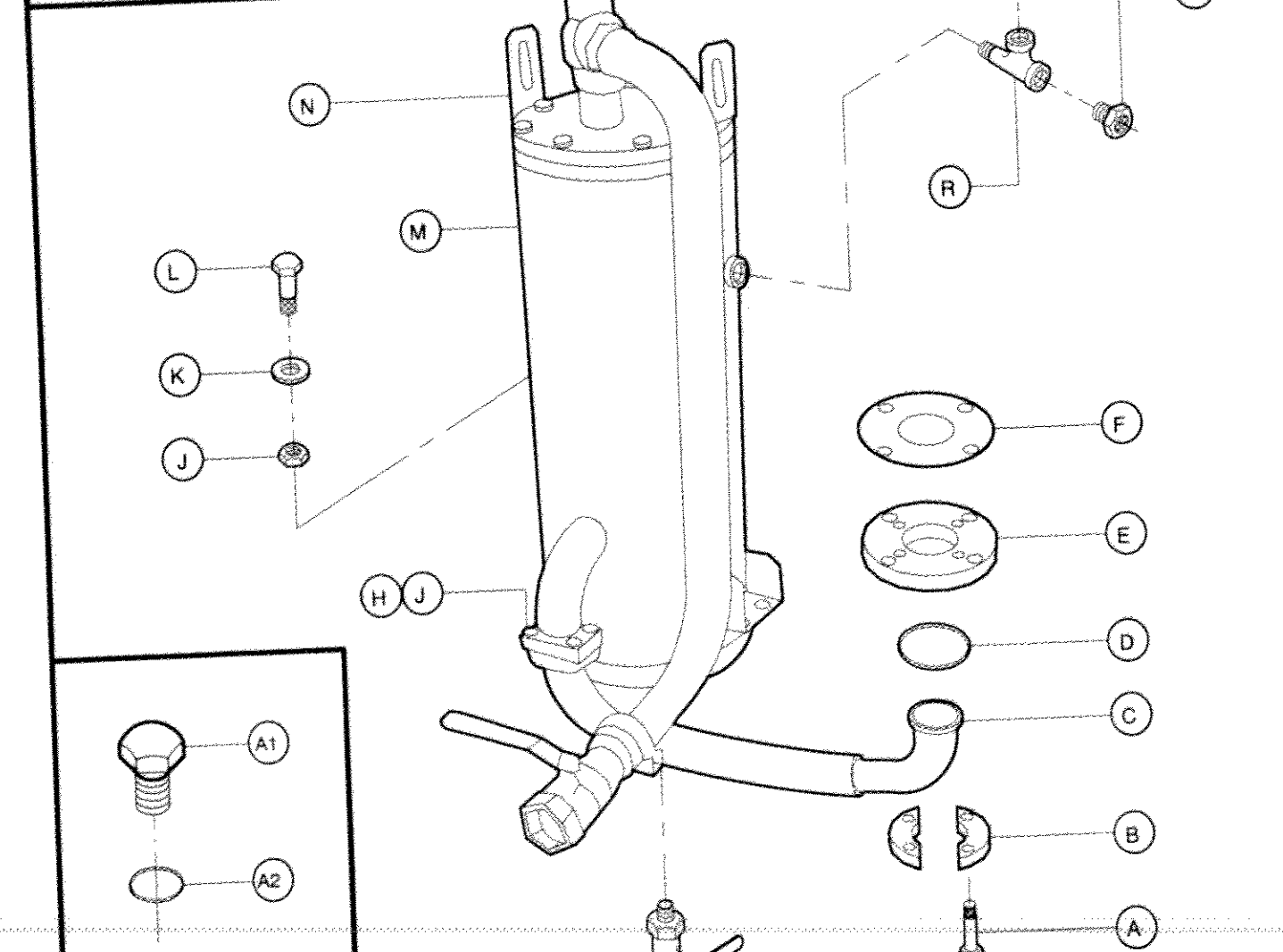
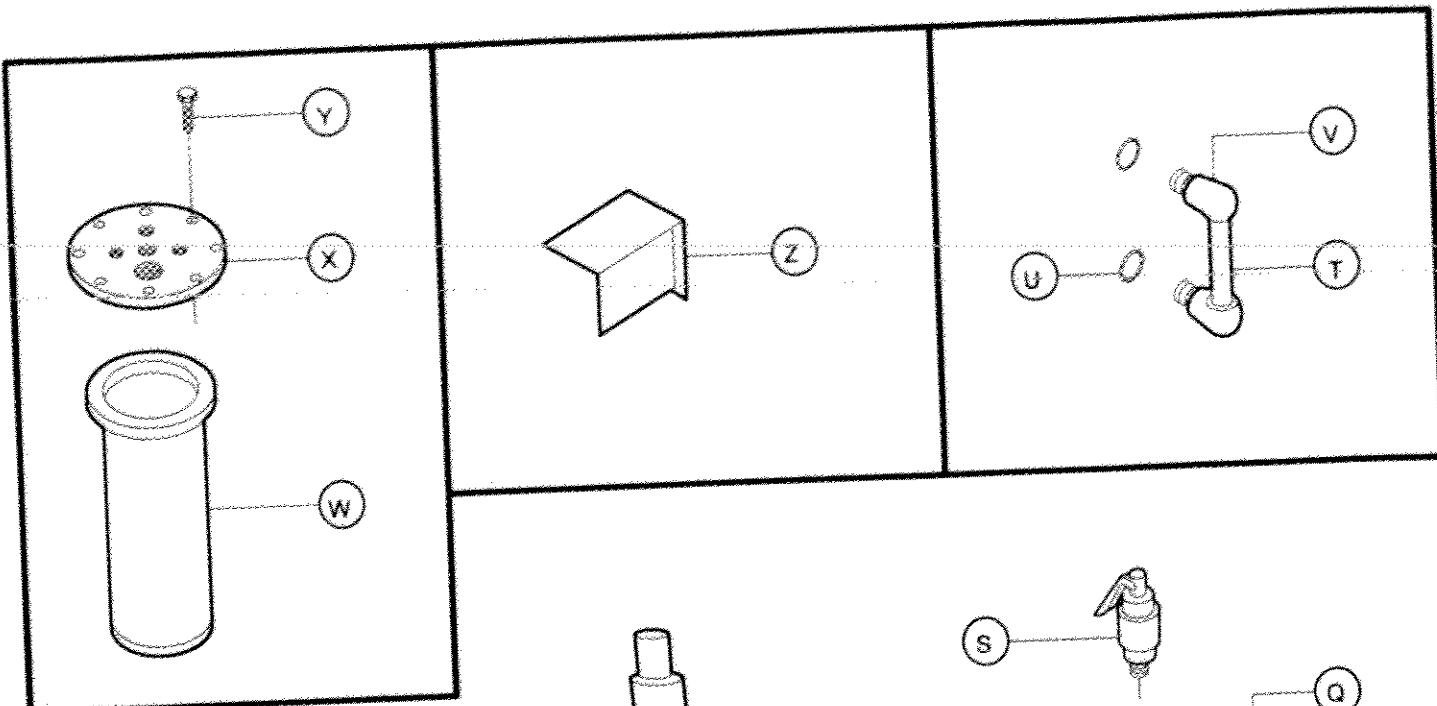

|  |  |                       |
|--|--|-----------------------|
| INGERSOLL-RAND COMPANY<br>PORTABLE COMPRESSOR DIVISION |  |                       |
| DATE/DRAWN BY:<br>2-00 WAP                             | DESCRIPTION<br>SEPARATOR TANK COMPLETE |                       |
| MODEL NO.<br>JD<br>DEUCE                               | MANUAL NO.<br>35389923-33              | DATE/REV.<br>2-00 / A |

|      |           |                                |                         |
|------|-----------|--------------------------------|-------------------------|
| (A)  | 36763888  | SCREW                          | ( 4 REQD )              |
| (B)  | 36866010  | FLANGE , SPLIT                 | ( 4 REQD )              |
| (C)  | 36865822  | HOSE , DISCHARGE               |                         |
| (D)  | 36866028  | O-RING                         |                         |
| (E)  | 36866002  | PLATE , ADAPTER                |                         |
| (F)  | 36865906  | GASKET                         |                         |
| (G)  | 36785080  | VALVE , BALL                   |                         |
| (H)  | 36773737  | SCREW                          | ( 4 REQD )              |
| (J)  | 36879203  | NUT                            | ( 4 REQD )              |
| (K)  | NOT USED  |                                |                         |
| (L)  | 36877793  | SCREW                          | ( 4 REQD )              |
| (M)  | 36865814  | TANK , SEPARATOR               | ( HP800WJD / XP750WJD ) |
|      | 36876381  | TANK , SEPARATOR               | ( HP750WJD / XP825WJD ) |
|      |           |                                | <i>54681721</i>         |
| (N)  | 36785012  | BRACKET                        | ( 2 REQD )              |
| (P)  | NOT USED  |                                |                         |
| (Q)  | 23A7S12Z1 | BUSHING                        |                         |
| (R)  | 35305275  | TEE , STREET                   |                         |
| (S)  | 36845030  | VALVE , SAFETY                 | ( HP800 / HP750 )       |
|      | 35326677  | VALVE , SAFETY                 | ( XP750 / XP825 )       |
| (T)  | 92121532  | TUBE , SIGHT                   |                         |
| (U)  | 35324649  | GASKET                         |                         |
| (V)  | 36860468  | FITTING                        |                         |
| (W)  | 36866218  | ELEMENT , SEPARATOR            |                         |
| (X)  | 36866879  | COVER , TANK                   |                         |
| (Y)  | 38179072  | SCREW                          | ( 8 REQD )              |
|      | 12A5D8Z1  | WASHER                         | ( 8 REQD )              |
| (Z)  | 36871812  | BRACKET , VALVE ( STANDARD )   |                         |
|      | 54492723  | BRACKET , VALVE ( GALVANNEAL ) |                         |
| (A1) | 35579630  | PLUG                           |                         |
| (A2) | 35279842  | O-RING                         |                         |

| INGERSOLL-RAND COMPANY<br>PORTABLE COMPRESSOR DIVISION |     |                         |  |
|--|-----|-------------------------|--|
| DATE/DRAWN BY  |     | DESCRIPTION             |  |
| 2-00   | WAP | SEPARATOR TANK COMPLETE |  |
| MODEL NO.  |     | MANUAL NO.              |  |
| JD<br>DEUCE  |     | 35389923-34             |  |
|  |     | DATE REV.               |  |
|  |     | 6-00 / B                |  |

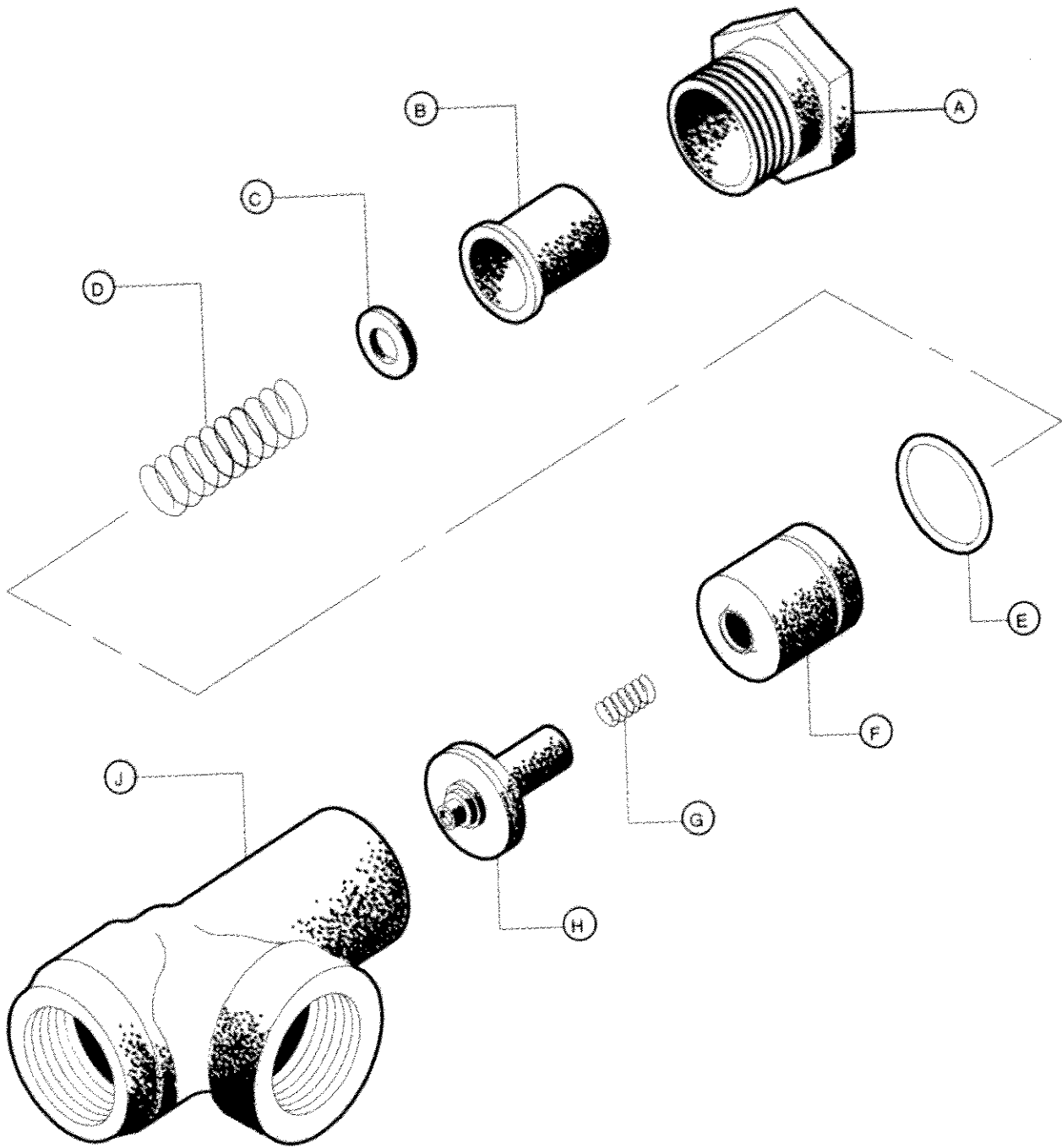

| INGERSOLL-RAND COMPANY<br>PORTABLE COMPRESSOR DIVISION |                                       |          |
|--|---------------------------------------|----------|
| DATE/DWN BY  | DESCRIPTION                           |          |
| 2-00 WAP   | MINIMUM PRESSURE CHECK VALVE ASSEMBLY |          |
| MODEL NO   | MANUAL NO                             | DATE/REV |
| JD<br>DEUCE  | 35389923-35                           | 2-00 / A |

|     |          |                      |
|-----|----------|----------------------|
| (A) | 35367341 | CAP                  |
| (B) | 35367390 | INSERT               |
| (C) | 11A5D6Z1 | WASHER               |
| (D) | 35367366 | SPRING               |
| (E) | 35367374 | O-RING               |
| (F) | 35367325 | PISTON               |
| (G) | 35367358 | SPRING               |
| (H) | 35367317 | CHECK VALVE ASSEMBLY |
| (J) | 35367333 | BODY                 |

MINIMUM PRESSURE CHECK VALVE ASSEMBLY

———— PART NUMBER 35598770

|  |  |                       |
|--|--|-----------------------|
| INGERSOLL-RAND COMPANY<br>PORTABLE COMPRESSOR DIVISION |  |                       |
| DATE/DOWN BY:<br>2-00 WAP                              | DESCRIPTION<br>MINIMUM PRESSURE CHECK VALVE ASSEMBLY |                       |
| MODEL NO.<br>JD<br>DEUCE                               | MATERIAL NO.<br>35389923-36                          | DATE/REV.<br>2-00 / A |

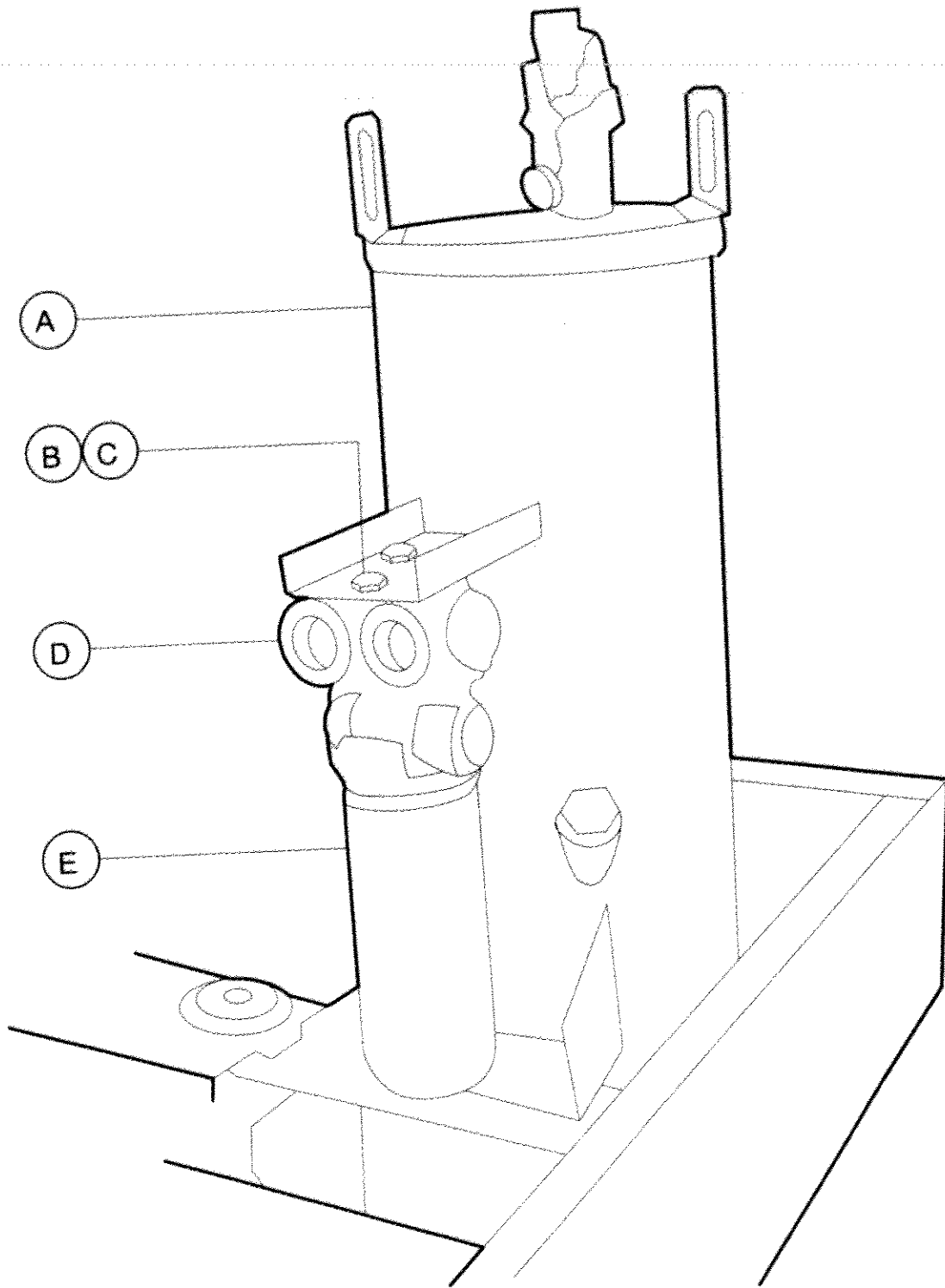

| INGERSOLL-RAND COMPANY<br>PORTABLE COMPRESSOR DIVISION |                                       |          |
|--|---------------------------------------|----------|
| DATE/DOWN BY:  | DESCRIPTION                           |          |
| 2-00 WAP   | OIL TEMPERATURE BYPASS VALVE & FILTER |          |
| MODEL NO   | MANUAL NO                             | DATE/REV |
| JD<br>DEUCE  | 35389923-37                           | 2-00 / A |

- (A) SEPARATOR TANK ( REFERENCE ONLY )
- (B) 34M2AB409M3 SCREW ( 3 REQD )
- (C) 12A5D4Z1 WASHER
- (D) 36871689 VALVE , BY-PASS
- (E) 36860336 FILTER

BYPASS VALVE KITS

- 35388024 RV REPAIR KIT
- 35388032 ELEMENT REPAIR KIT
- 35388040 O-RING REPAIR KIT

|   |     |                                       |          |
|---|-----|---------------------------------------|----------|
| <b>INGERSOLL-RAND COMPANY</b><br>PORTABLE COMPRESSOR DIVISION |     |                                       |          |
| DATE/DOWN BY  |     | DESCRIPTION                           |          |
| 2-00  | WAP | OIL TEMPERATURE BYPASS VALVE & FILTER |          |
| MODEL NO.   |     | MANUAL NO.                            | DATE/REV |
| JD<br>DEUCE   |     | 35389923-38                           | 2-00 / A |



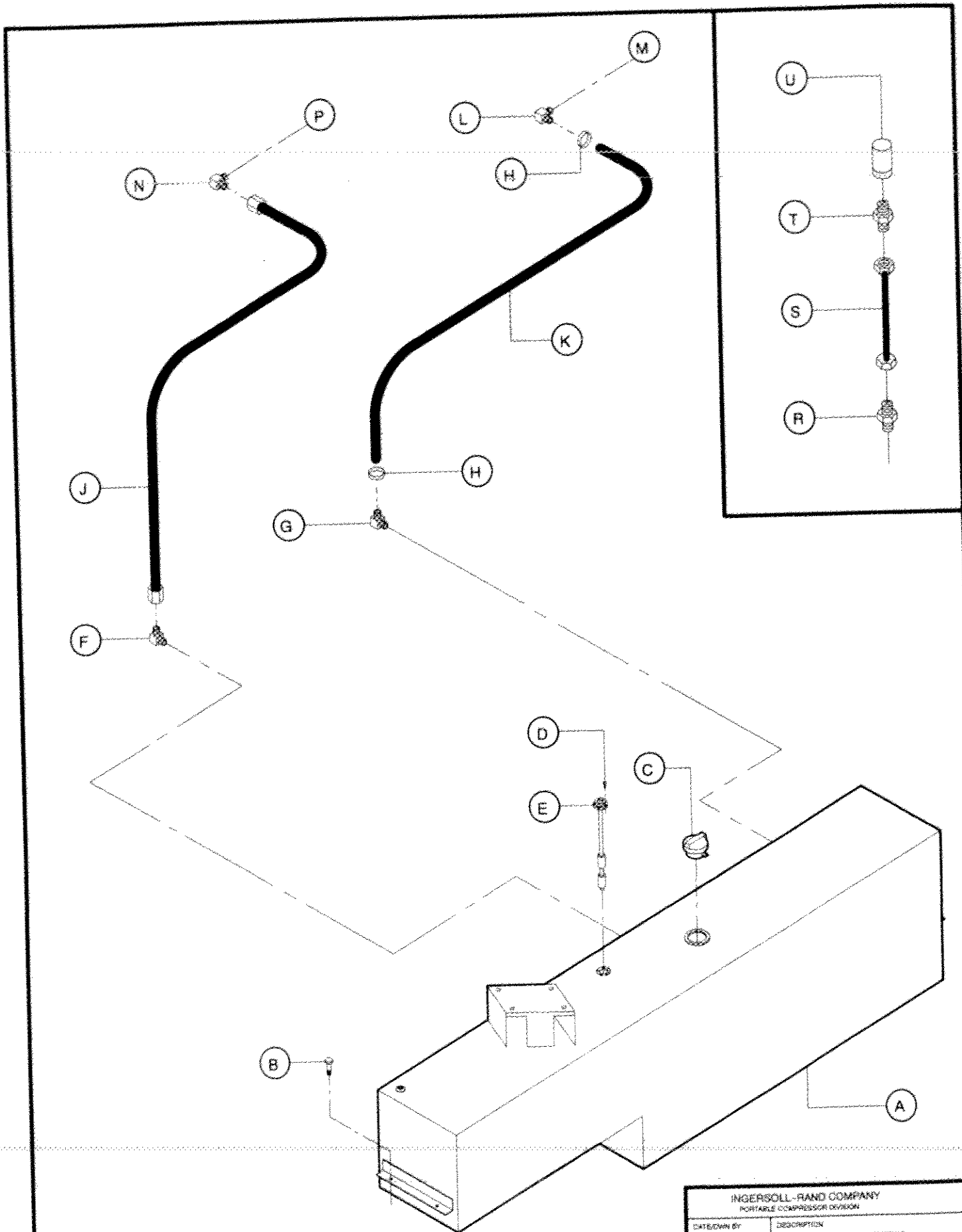

| INGERSOLL-RAND COMPANY<br>PORTABLE COMPRESSOR DIVISION |                      |           |
|--|----------------------|-----------|
| DATE/DOWN BY   | DESCRIPTION          |           |
| 2-00 WAP   | FUEL TANK AND PIPING |           |
| MODEL NO.  | MANUAL NO.           | DATE/REV. |
| JD DEUCE   | 35389923-39          | 2-00 / A  |

|     |          |                      |                                      |
|-----|----------|----------------------|--------------------------------------|
| (A) | 36887750 | TANK , FUEL          |                                      |
|     | 36886547 | TANK , FUEL          | ( CLEAN-OUT OPTION TANK , 36026763 ) |
| (B) | 35279025 | SCREW                | ( 4 REQD )                           |
| (C) | 36845014 | CAP , FUEL FILLER    |                                      |
| (D) | 36842102 | SCREW                | ( 5 REQD )                           |
| (E) | 36845402 | SENDER , FUEL LEVEL  | ( HP600WJD / XP750WJD )              |
|     | 36876845 | SENDER , FUEL LEVEL  | ( HP750WJD / XP825WJD )              |
| (F) | 35279934 | ELBOW , 90 °         |                                      |
| (G) | 35322668 | ELBOW , 90 °         |                                      |
| (H) | 35296342 | CLAMP                |                                      |
| (J) | 35311471 | HOSE ASSEMBLY        | ( HP600WJD / XP750WJD )              |
|     | 35282987 | HOSE ASSEMBLY        | ( HP750WJD / XP825WJD )              |
| (K) | 35282078 | HOSE                 | ( 32 INCHES )                        |
| (L) | 35322460 | UNION                |                                      |
| (M) |          | TO FUEL RETURN       |                                      |
| (N) | 35322668 | ELBOW                |                                      |
| (P) |          | TO ENGINE PRIME PUMP |                                      |
| (Q) | 36867984 | PAD , FUEL TANK      | ( NOT ILLUSTRATED )                  |
| (R) | 35369347 | CONNECTOR            |                                      |
| (S) | 35356484 | TUBING               | ( 16 INCHES )                        |
| (T) | 35369339 | CONNECTOR            |                                      |
| (U) | 35322395 | SILENCER             |                                      |

| INGERSOLL-RAND COMPANY<br>PORTABLE COMPRESSOR ENGINE |                      |           |
|--|----------------------|-----------|
| DATE/DRAWN BY  | DESCRIPTION          |           |
| 2-00 WAP   | FUEL TANK AND PIPING |           |
| MODEL NO.  | MANUAL NO.           | DATE/REV. |
| JG<br>DEUCE  | 35389923-40          | 11-01 / B |

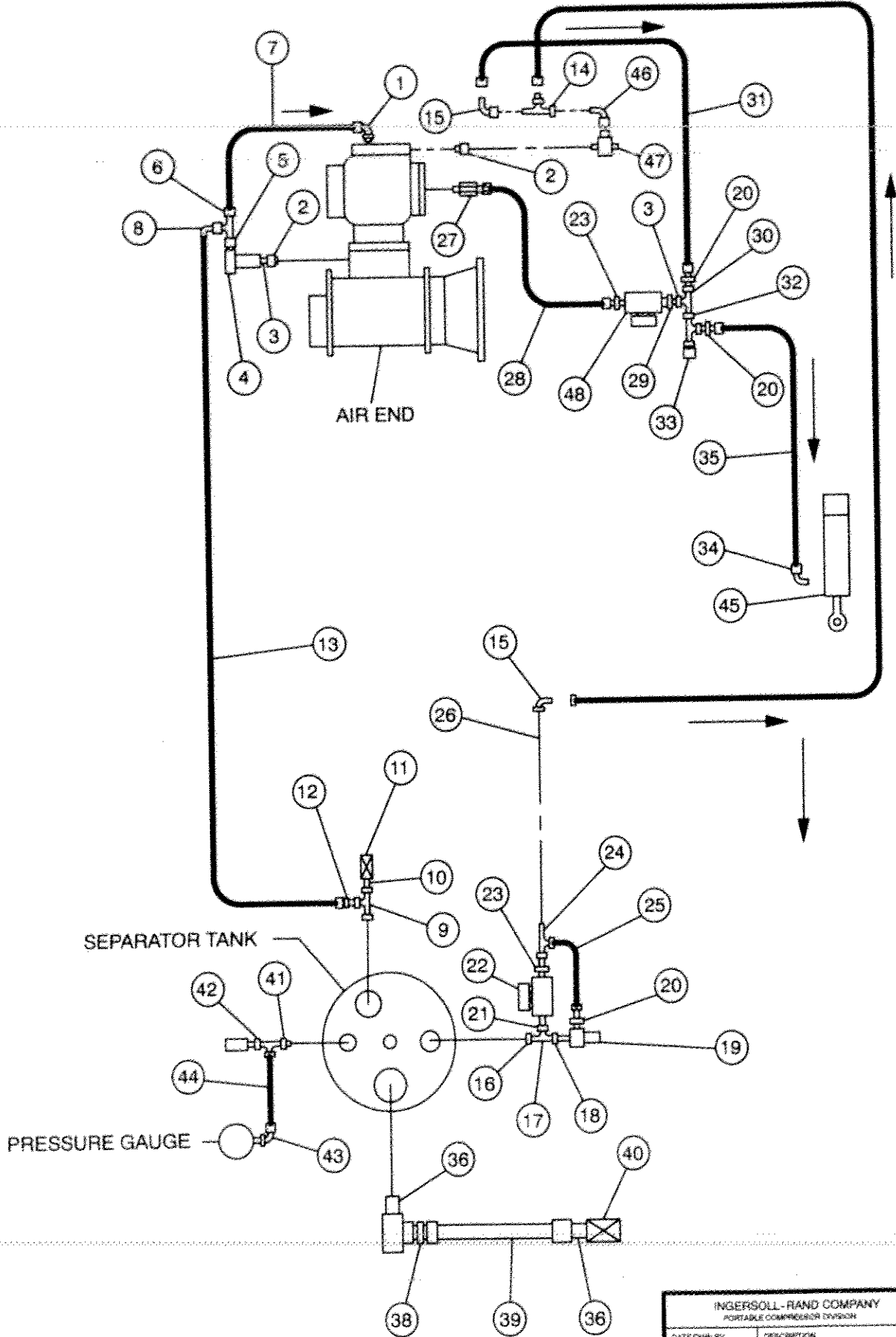

| INGERSOLL-RAND COMPANY<br>PORTABLE COMPRESSOR DIVISION |             |  |            |
|--|-------------|--|------------|
| DATE/DWY BY  | DESCRIPTION |  | AIR PIPING |
| 2-00   | WAP         |  |            |
| MODEL NO.  | MANUAL NO.  |  | DATE REV.  |
| JD   | 35389923-41 |  | 2-00 / A   |
| DEUCE  |             |  |            |

|    |          |  |
|----|----------|--|
| 1  | 35287937 | ELBOW , 90                                   |
| 2  | 35300214 | ADAPTER                                      |
| 3  | 19A7J22  | NIFFLE , CLOSE                               |
| 4  | 35322379 | VALVE , SLOWDOWN                             |
| 5  | 35283194 | CONNECTOR                                    |
| 6  | 35287929 | TEE , SWIVEL                                 |
| 7  | 35287176 | TUBE   |
| 8  | 35287911 | ELBOW , 90                                   |
| 9  | 72A7M5Z1 | TEE , STREET                                 |
| 10 | 19A7J5Z1 | NIFFLE , CLOSE                               |
| 11 | 35376115 | VALVE , SLOWDOWN                             |
| 12 | 35313287 | ADAPTER                                      |
| 13 | 35305473 | HOSE   |
| 14 | 35283064 | TEE , RUN                                    |
| 15 | 35282068 | ELBOW , 90                                   |
| 16 | 35A7S5Z1 | BUSHING , REDUCING                           |
| 17 | 35283050 | TEE , RUN                                    |
| 18 | 35287846 | ADAPTER                                      |
| 19 | 36854149 | VALVE , PRESSURE REGULATOR ( XP750 / XP825 ) |
| 19 | 36854495 | VALVE , PRESSURE REGULATOR ( HP600 / HP750 ) |
| 20 | 35284082 | ADAPTER                                      |
| 21 | 35368927 | ADAPTER                                      |
| 22 | 36840841 | VALVE , SOLENOID                             |
| 23 | 35290147 | ADAPTER                                      |
| 24 | 35283064 | TEE , SWIVEL                                 |
| 25 | 35282953 | HOSE   |
| 26 | 35323724 | HOSE   |
| 27 | 36840460 | VALVE , RELIEF / CHECK                       |
| 28 | 36867554 | TUBE   |
| 29 | 35A7S2Z1 | BUSHING , REDUCING                           |
| 30 | 71A7M2Z1 | TEE  |
| 31 | 35282961 | TUBE   |
| 32 | 72A7M5Z1 | TEE , STREET                                 |
| 33 | 35322346 | CONNECTOR                                    |
| 34 | 35301155 | ELBOW , 90                                   |
| 35 | 35280019 | HOSE   |
| 36 | 19A7S5Z1 | NIFFLE                                       |
| 37 | 35526770 | VALVE , MINIMUM PRESSURE                     |
| 38 | 35335124 | ADAPTER                                      |
| 39 | 35827067 | TUBE , SERVICE AIR ( HP800WCU / XP750WCU )   |
| 39 | 35827069 | TUBE , SERVICE AIR ( HP750WCU / XP825WCU )   |
| 40 | 35932473 | VALVE , BALL                                 |
| 41 | 25A7S5Z1 | BUSHING , REDUCING                           |
| 42 | 35326503 | TEE , STREET                                 |
| 43 | 35301225 | ELBOW , STREET                               |
| 44 | 35331848 | HOSE   |
| 45 | 35523144 | CYLINDER , AIR                               |
| 46 | 35275934 | ELBOW  |
| 47 | 35661951 | VALVE , FLOW CONTROL                         |
| 48 | 36861944 | VALVE , SOLENOID                             |

.156"

| INGERSOLL-RAND COMPANY    |             |          |
|---------------------------|-------------|----------|
| PORTABLE COMPRESSOR DRUGS |             |          |
| DATE/OWN BY:              | DESCRIPTION |          |
| 2-00 WAP                  | AIR PIPING  |          |
| MODEL NO.                 | MANUAL NO.  | DATE/REV |
| JD DEUCE                  | 35389923-42 | 2-00 / A |

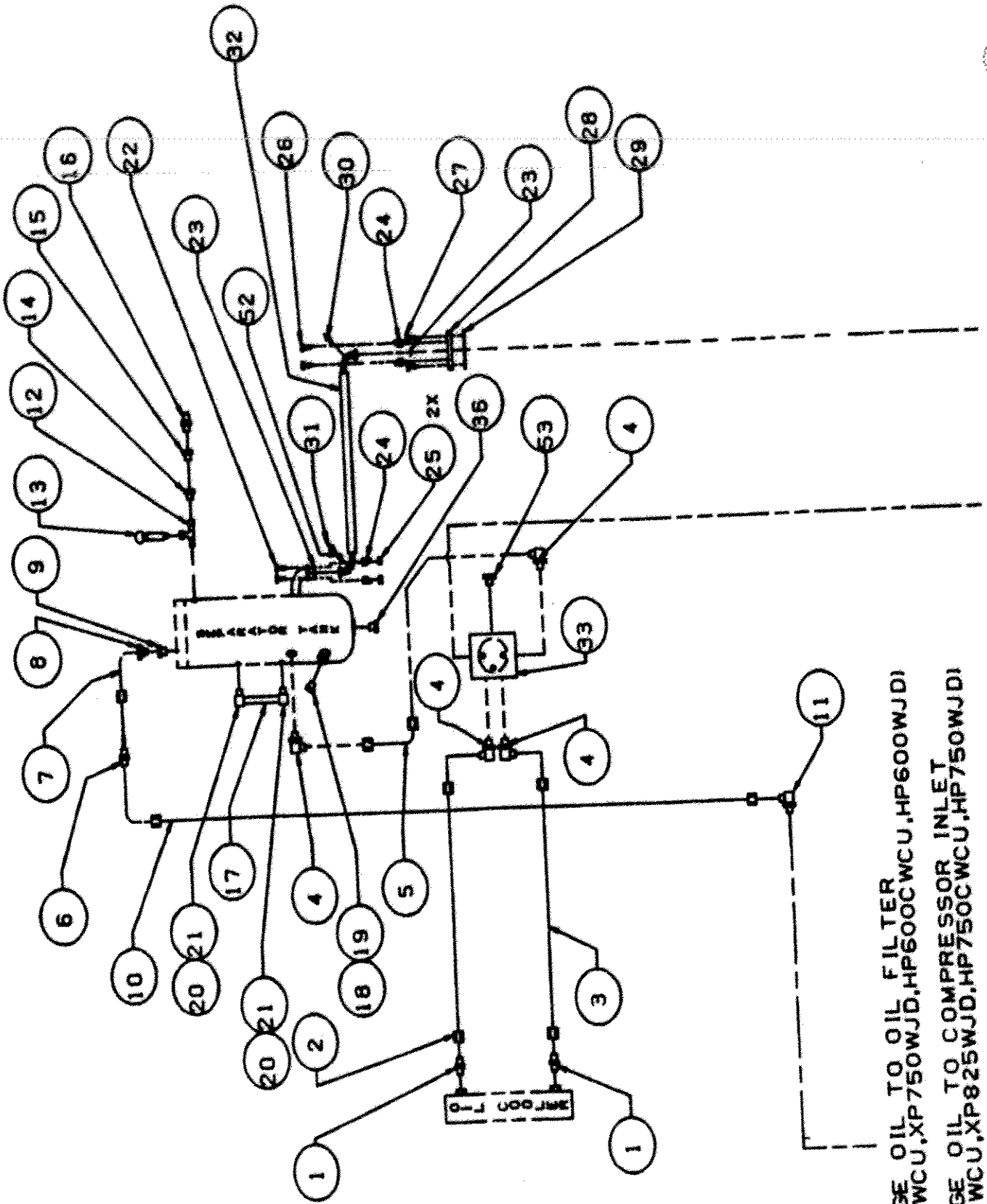

SCAVENGE OIL TO OIL FILTER  
 (XP750CWCU,XP750WJD,HP600CWCU,HP600WJD)  
 SCAVENGE OIL TO COMPRESSOR INLET  
 (XP825CWCU,XP825WJD,HP750CWCU,HP750WJD)

| NO. | PART NO.             | DESCRIPTION  |
|-----|----------------------|--|
| 1   | 36846061<br>36877355 | ST. COHN. 1.625-12 W/O-RING<br>CONN-20X7.25 (XP825WJD ONLY)  |
| 2   | 36866226             | TUBE ASSY-UPPER  |
| 3   | 36866234             | TUBE ASSY-LOWER  |
| 4   | 35279777             | ELB. COHN. 1.625-12 W/O-RING   |
| 5   | W90376               | HOSE ASSY  |
| 6   | 36840411             | CHECK VALVE  |
| 7   | 36867737             | TUBE ASSY  |
| 8   | 35329309             | LENZ FITTING   |
| 9   | 23A758Z1             | RED. BUSH .75 NPT - .375 NPT   |
| 10  | 35282912<br>36877751 | HOSE ASSY (XP750CWCU,XP750WJD,HP600CWCU,HP600WJD)<br>HOSE ASSY (XP825CWCU,XP825WJD,HP750CWCU,HP750WJD)                               |
| 11  | 35279876<br>35279827 | ELBOW 90° .437-20X-4 JIC (XP750CWCU,XP750WJD,HP600CWCU,HP600WJD)<br>ELBOW 90° .562-18X-6 JIC (XP825CWCU,XP825WJD,HP750CWCU,HP750WJD) |
| 12  | 35305275             | TEE STREET. 1.0 NPT  |
| 13  | 35326677<br>36845030 | SAFETY VALVE 175 PSI (XP750CWCU,XP750WJD,XP825CWCU,XP825WJD)<br>SAFETY VALVE 200 PSI (HP600CWCU,HP600WJD,HP750CWCU,HP750WJD)         |
| 14  | 23A7512Z1            | RED. BUSHING 1.0 NPT - .50 NPT   |
| 15  | 23A755Z1             | RED. BUSHING .50 NPT - .25 NPT   |
| 16  | 36757573             | SWITCH SHUTDOWN  |
| 17  | 92121532             | TUBE, SIGHT  |
| 18  | 35579630             | PLUG, VENTED 1.625   |
| 19  | 35279942             | O-RING   |
| 20  | 36804068             | SIGHT TUBE FITTING   |
| 21  | 35324649             | GASKET   |
| 22  | 36773737             | SCREW, SOCKET HEAD M12-1.75 X 60LG   |
| 23  | 36866028             | O-RING   |
| 24  | 36866010             | SPLIT FLANGE SAE -40   |
| 25  | 16M4JC24M3           | NUT HEX M12 X 1.75   |
| 26  | 36763688             | SCREW M12 - 1.75 X 35LG  |
| 27  | 35375385             | SCREW HEX M16 - 2.00 X 40LG  |
| 28  | 36866002             | FLANGE ADAPTOR   |
| 29  | 36865996             | GASKET   |
| 30  | 36865756             | SW. SHUTDOWN   |
| 31  | 35367218             | TEMPERATURE SENDER   |
| 32  | 36865822             | HOSE ASSY. - DISCHARGE   |
| 33  | 36871689             | VALVE BYPASS   |
| 34  | W90434               | HOSE ASSY.   |
| 35  | 36868008             | REDUCER JIC -24 -20  |
| 36  | 36795680             | VALVE - BALL   |
| 37  | 36866531             | MANIFOLD   |
| 38  | 36865889             | TUBE ASSY  |
| 39  | 36866564             | STRAIGHT CONN .437 - 20 X -6 JIC   |
| 40  | 36865897             | TUBE ASSY  |
| 41  | 35305622             | ELBOW, 90° .75-16 X -10 JIC W/O-RING   |
| 42  | 35305648             | ELBOW, SWIVEL 90° .750 - 16 X -10 JIC  |
| 43  | 36865921             | TUBE ASSY  |
| 44  | 35356450             | TEE SWIVEL .875 - 14 X -10 JIC   |
| 45  | 35856251             | TUBE ASSY  |
| 46  | 35305648             | ELBOW, 90° .750 - 16 X -10 JIC   |
| 47  | 35286954             | STRAIGHT CONN .875 - 14 X - 10 JIC   |
| 48  | 36865905             | TUBE ASSY  |
| 49  | 35279827             | ELBOW 90° .562 - 18 X -6 JIC   |
| 50  | 36865913             | TUBE ASSY  |
| 51  | 36866572             | ELBOW 90° .437 - 20 X -6 JIC   |
| 52  | 23A754Z1             | RED. BUSH .50NPT - .375 NPT  |
| 53  | 35289057             | PLUG, .437-20 (XP825CWCU,XP825WJD,HP750CWCU,HP750WJD)  |

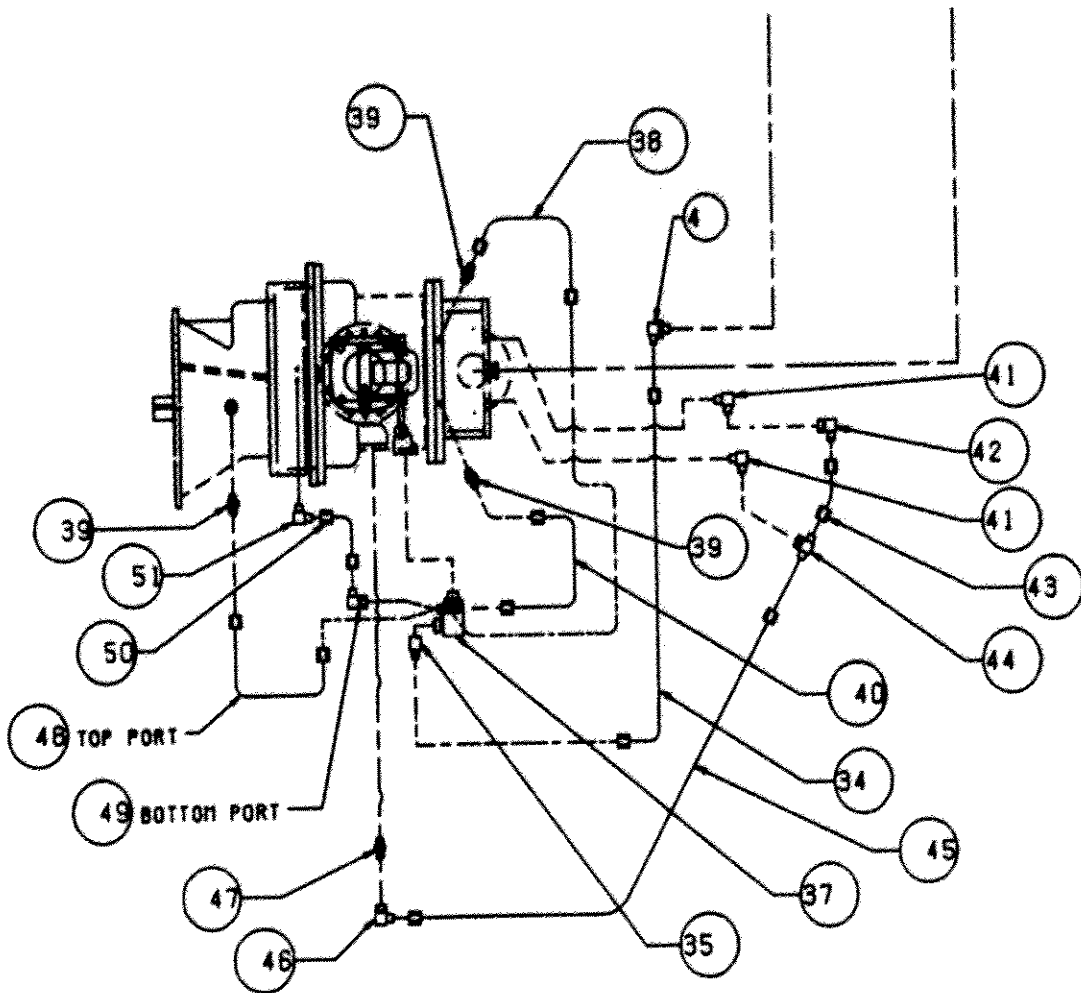

| NO. | PART NO.             | DESCRIPTION  |
|-----|----------------------|--|
| 1   | 36846061<br>36877355 | ST. CONN. 1.625-12 W/O-RING<br>CONN-20X7.25 (XP825WJD ONLY)  |
| 2   | 36866226             | TUBE ASSY-UPPER  |
| 3   | 36866234             | TUBE ASSY-LOWER  |
| 4   | 35279777             | ELB. CONN. 1.625-12 W/O-RING   |
| 5   | W50376               | HOSE ASSY  |
| 6   | 36840411             | CHECK VALVE  |
| 7   | 36867737             | TUBE ASSY  |
| 8   | 35329309             | LENZ FITTING   |
| 9   | 23A75821             | RED. BUSH .75 NPT - .375 NPT   |
| 10  | 35282912<br>36877751 | HOSE ASSY (XP750CWCU,XP750WJD,HP600CWCU,HP600WJD)<br>HOSE ASSY (XP825CWCU,XP825WJD,HP750CWCU,HP750WJD)                               |
| 11  | 35279876<br>35279827 | ELBOW 90° .437-20X-4 JIC (XP750CWCU,XP750WJD,HP600CWCU,HP600WJD)<br>ELBOW 90° .562-18X-6 JIC (XP825CWCU,XP825WJD,HP750CWCU,HP750WJD) |
| 12  | 35305275             | TEE STREET, 1.0 NPT  |
| 13  | 35326677<br>36848030 | SAFETY VALVE 175 PSI (XP750CWCU,XP750WJD,XP825CWCU,XP825WJD)<br>SAFETY VALVE 200 PSI (HP600CWCU,HP600WJD,HP750CWCU,HP750WJD)         |
| 14  | 23A751221            | RED. BUSHING 1.0 NPT - .50 NPT   |
| 15  | 23A75521             | RED. BUSHING .50 NPT - .25 NPT   |
| 16  | 36757573             | SWITCH SHUTDOWN  |
| 17  | 92121532             | TUBE, SIGHT  |
| 18  | 35579630             | PLUG, VENTED 1.625   |
| 19  | 35279942             | O-RING   |
| 20  | 36804068             | SIGHT TUBE FITTING   |
| 21  | 35324649             | GASKET   |
| 22  | 36773737             | SCREW, SOCKET HEAD M12-1.75 X 60LG   |
| 23  | 36866028             | O-RING   |
| 24  | 36866010             | SPLIT FLANGE SAE -40   |
| 25  | 16M4JC24M3           | NUT HEX M12 X 1.75   |
| 26  | 36763688             | SCREW M12 - 1.75 X 35LG  |
| 27  | 35375385             | SCREW HEX M16 - 2.00 X 40LG  |
| 28  | 36866002             | FLANGE ADAPTOR   |
| 29  | 36865996             | GASKET   |
| 30  | 36865756             | SW. SHUTDOWN   |
| 31  | 35367218             | TEMPERATURE SENDER   |
| 32  | 36865822             | HOSE ASSY. - DISCHARGE   |
| 33  | 36871689             | VALVE BYPASS   |
| 34  | W90434               | HOSE ASSY.   |
| 35  | 36868008             | REDUCER JIC -24 -20  |
| 36  | 36795680             | VALVE - BALL   |
| 37  | 36866531             | MANIFOLD   |
| 38  | 36865889             | TUBE ASSY  |
| 39  | 36866564             | STRAIGHT CONN .437 - 20 X -6 JIC   |
| 40  | 36865897             | TUBE ASSY  |
| 41  | 35305622             | ELBOW, 90° .75-16 X -10 JIC W/O-RING   |
| 42  | 35305648             | ELBOW, SWIVEL 90° .750 - 16 X -10 JIC  |
| 43  | 36865921             | TUBE ASSY  |
| 44  | 35356450             | TEE SWIVEL .875 - 14 X -10 JIC   |
| 45  | 35856251             | TUBE ASSY  |
| 46  | 35305648             | ELBOW, 90° .750 - 16 X -10 JIC   |
| 47  | 35286954             | STRAIGHT CONN .875 - 14 X - 10 JIC   |
| 48  | 36865905             | TUBE ASSY  |
| 49  | 35279827             | ELBOW 90° .562 - 18 X -6 JIC   |
| 50  | 36865913             | TUBE ASSY  |
| 51  | 36866572             | ELBOW 90° .437 - 20 X -6 JIC   |
| 52  | 23A75421             | RED. BUSH .50NPT - .375 NPT  |
| 53  | 35289057             | PLUG, .437-20 (XP825CWCU,XP825WJD,HP750CWCU,HP750WJD)  |



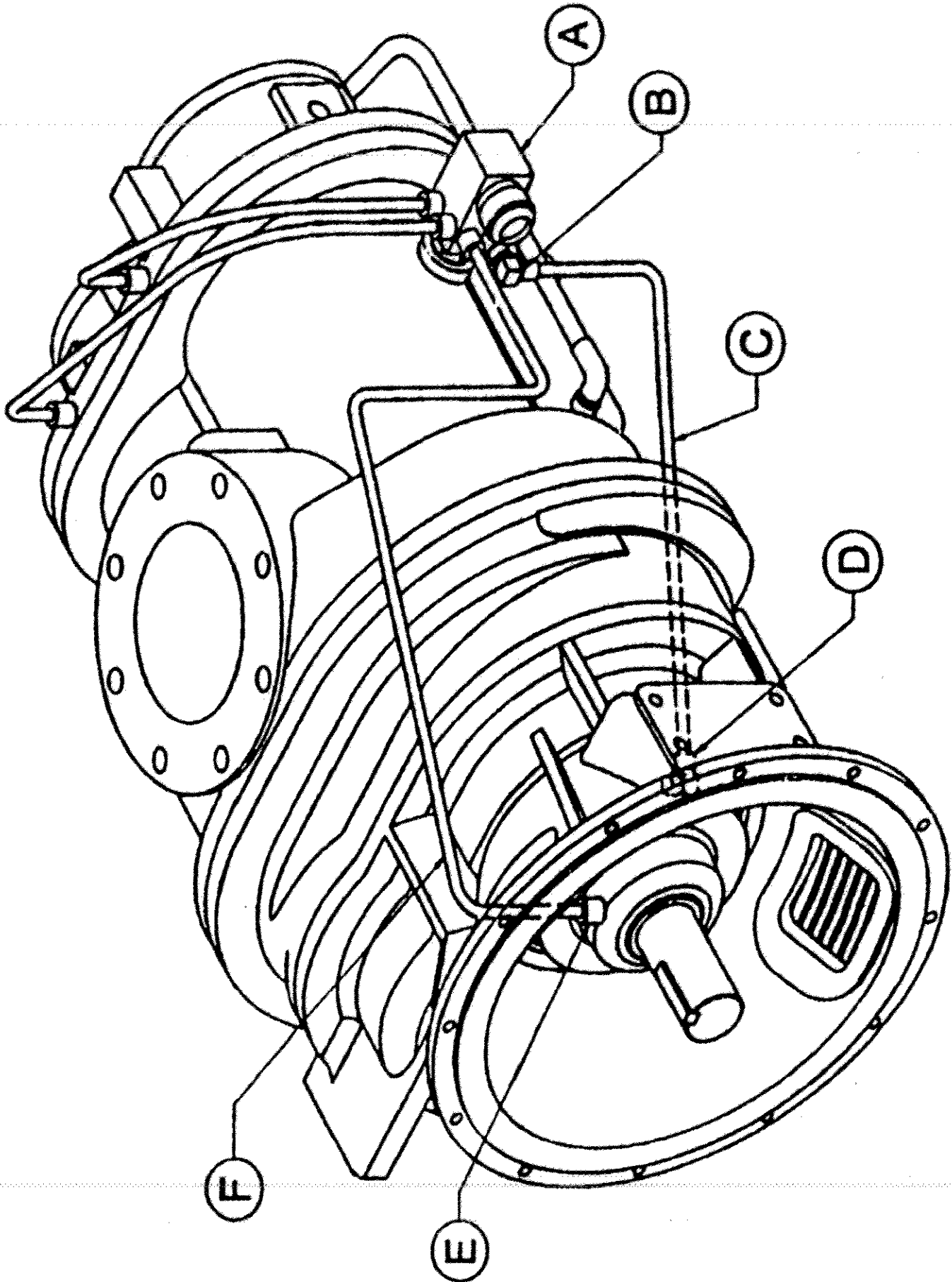

- (A) 36866531 OIL MANIFOLD
- (B) 35279827 ELBOW , 90 °
- (C) 36865913 TUBE , FRONT BEARINGS
- (D) 36866572 ELBOW , 90 °
- (E) 36866564 CONNECTOR
- (F) 36865905 SEAL TUBE

|  |             |                |  |
|--|-------------|----------------|--|
| INGERSOLL-RAND COMPANY<br>PORTABLE COMPRESSOR DIVISION |             |                |  |
| DATE DRAWN BY  |             | DESCRIPTION    |  |
| 2-00   | WAP         | AIR END PIPING |  |
| MODEL NO.  | MANUAL NO.  | DATE REV.      |  |
| JD<br>DEVICE   | 35389923-48 | 2-00 / A       |  |